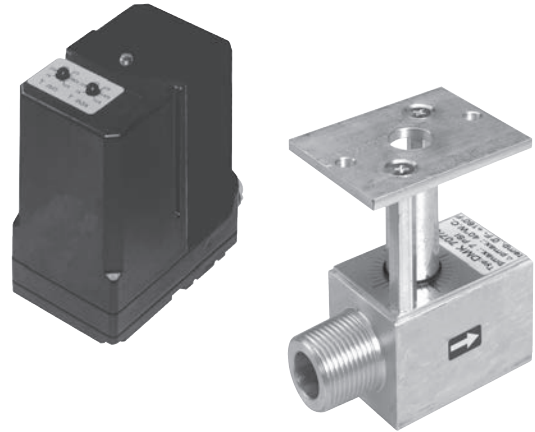



Table of Contents

Table of Contents Page 1
 Approvals DMA Page 1
 Approvals DMK Page 1
 Attention Page 1
 Specification DMA Page 2
 Specification DMK Page 2
 Maintenance and Testing Page 2
 Mounting Page 3
 Wiring the DMA Page 3
 DMA Actuator Calibration and Adjustments .. Page 4



Approvals DMA

 UL Recognized Component: File No. E142163  CSA Certified: File No. 157406-1378915

Commonwealth of Massachusetts Approved Product Approval code G1-1107-35

Approvals DMK

 UL Listed Component: File No. MH 18741

Commonwealth of Massachusetts Approved Product Approval code G1-1107-35

Attention



The installation and maintenance of this product must be done under the supervision of an experienced and trained specialist. Never perform work if gas pressure or power is applied, or in the presence of an open flame.



On completion of work on the Motor Actuator and Butterfly Control Valve, perform a leakage and function test.



Please read the instruction before installing or operating. Keep the instruction in a safe place. You find the instruction also at www.dungs.com If these instructions are not heeded, the result may be personal injury or damage to property.



This product is intended to be used in combination with a control valve to modulate the flow of gas or air.



Any adjustment and application-specific adjustment values must be made in accordance with the equipment manufacturers instructions.

Explanation of symbols

- 1, 2, 3 ... = Action
- = Instruction

Specification DMA

DMA The actuator drives from 0 to 90 degrees via 4 - 20 mA input signal. It can move in any direction and stop anywhere over the entire 90 degree stroke.



Electrical Rating
110 - 120 VAC (+10/-15%) 50 - 60 Hz
Max. Power Rating
2.0 VA Holding, 5.4 VA Operating

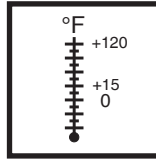

Ambient Temperature
+15 °F to +120 °F (-10 °C to +50 °C)

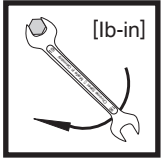

Max. Torque Ratings

Timing	Holding	Operating
6	12.4 in-lb	5.3 in-lb
12	24.8 in-lb	8.9 in-lb
30	26.5 in-lb	17.7 in-lb

Position Resolution
0.25 mA resolution; minimum of 1.6° per step

Max. Contact Rating for Auxiliary Switch

1.5 Amps at 120 VAC 50/60 Hz

Input Control

4 to 20 mA

Position Feedback or Slave Output
4 to 20 mA; 500 ohm maximum impedance. Resistance across terminals 8 & 10 is 250 Ohms.

Repeatability: max +/- 2°

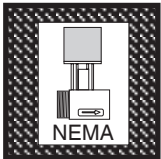

Enclosure Rating
NEMA Type 1/IP 40 enclosure (standard with DMA)

Specification DMK

DMK/6 The butterfly control valve actuates from 0 to 90 degrees in either direction; it is not a tight shut-off valve. Input-side male thread and output-side female thread enable assembly directly to DUNGS shutoff valves.



Max. Pressure
7 PSI (500 mbar) MH 194167
Max. Differential Pressure for Optimal Performance
3.6 PSI (250 mbar)
Max. Body Pressure
15 PSI (1000 mbar)

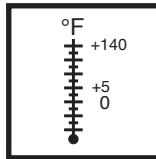

Ambient Temperature
+5 °F to +140 °F (-15 °C to +60 °C)

Actuator angle
90 degrees from open to closed

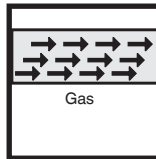

Gases

Dry, natural gas, propane, butane; other noncorrosive gases. Suitable for up to 0.1 % by volume, dry H₂S. A "dry" gas has a dew point lower than +15 °F and its relative humidity is less than 60 %.

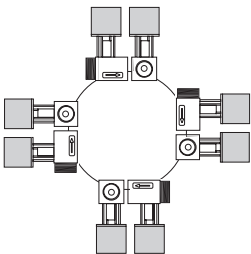

Mounting Position
Multipositioned

Maintenance and Testing

This product must be tested at least annually for safe and proper operation on the application on which the DMK/DMA is installed. Verify all inlet and outlet gas connections are leak tight. Verify linkage between DMK and DMA is tight. Verify DMK/DMA assembly drives to its proper positions according

to the input signals as defined by the application. Verify DMA limit switches trip at the proper setting and prevent DMA for driving beyond the position limited by the limit switches. Verify, auxiliary switch, if used, changes state when actuated by internal cam and that it's adjusted correctly.

Mounting

Mounting DMA to a DMK/6 butterfly valve

1. Remove the clear cover from the DMA.
2. Insert the shaft from the DMA into the linkage of the DMK/6 until the motor is flush on the DMK/6 mounting plate. Snug the set screw with a 2.5 mm allen wrench. Torque to 15 lb-in.
3. Insert the M5 x 55 mounting bolts (supplied) through the DMA motor mounting holes. Take care not to break the plastic covers off of the bolt holes. Hand tighten the 8 mm hex nuts that are supplied. Torque the bolts to 45 lb-in.

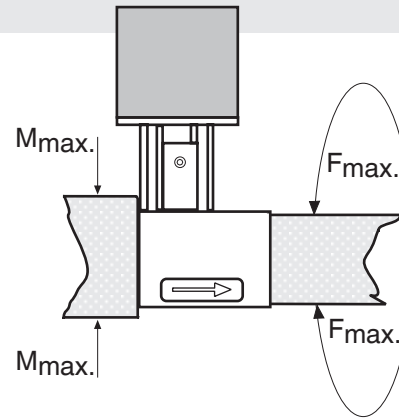

Mounting the DMK/6 to a shutoff valve

1. Turn off the gas supply.
2. Refer to the flow direction on the valve housing.
3. **Note:** Aluminum to Aluminum connection:
Coat inner and outer threads with a suitable lubricant before sealing the inner and outer threads.
4. **DO NOT** use any part of the DMA or the mounting bracket of the DMK/6 assembly as a lever to tighten! Use appropriate sized wrench.
5. Tighten connections. Use the chart below for torque specifications.
6. Perform a complete leak test after installation.

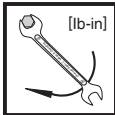
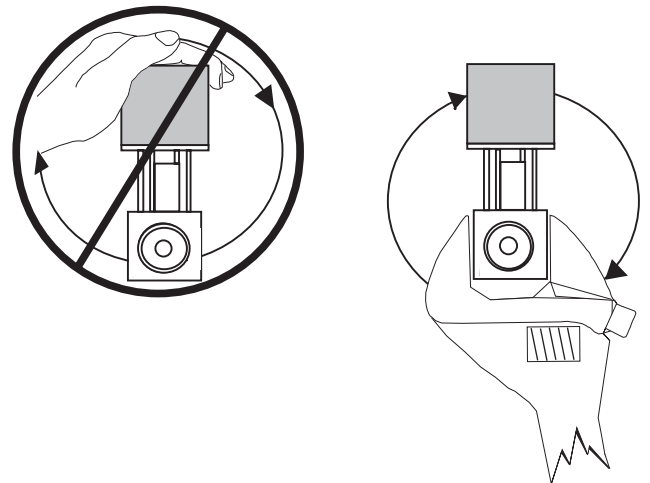

DMK	707	710	712	715	720
Max. lb-in	560	750	875	940	1190

Wiring the DMA

1. Remove all power supplies.
2. Use minimum AWG #16 class 1 wiring for all terminals.
3. Remove cover to access the terminal block.
4. Only use the specified terminals. Terminal 8 must be the + input and terminal 10 must be the - input.
5. The cover has an integrated protective barrier that physically separates the wiring from the moving adjustment switches and cams. Wiring must be properly routed so that the cover can be installed.
6. For terminals 8 and 10, use properly shielded wires, that are grounded on both sides, and run through conduit containing only low voltage (24 V) wiring.

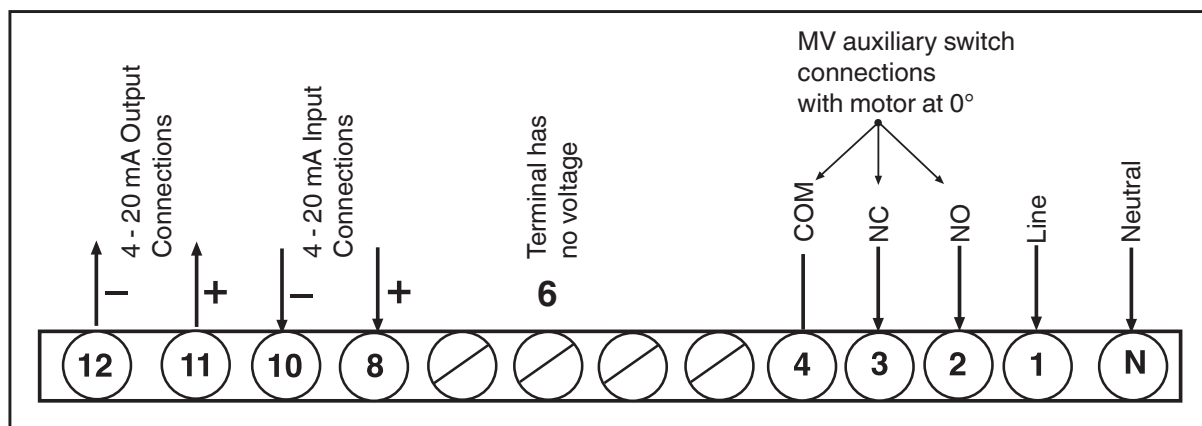

DMA Actuator Calibration and Adjustments

Calibrating the DMA

Note: The red and yellow switches are factory set outside of the 0 to 90° operating range. Do not change these adjustment dials until calibration is complete. **DO NOT** use these switches in lieu of the calibration.

To Adjust Minimum Position

1. Apply a 4 mA DC input signal.
2. Turn the **Y min** (Zero) potentiometer (adjusting range 0 to 100 % of stroke) to position the actuator at the desired minimum position. Turning **Y min** (Zero) CCW drives the minimum position towards 0°.

To Adjust Maximum Position

1. Apply 20 mA DC input signal.
2. Turn the **Y max** (Span) potentiometer (adjusting range 25 to 100 % of stroke) to position the actuator at the desired maximum position. Turning **Y max** (Span) CCW drives the setpoint towards 0°.

Note: Y min (Zero) must be no more than 75 % of **Y max** (Span) (reference: 90° = 100 %). E.g. if the maximum position is set at 85°, the minimum position can be set at 64° maximum. ($85^\circ \cdot 0.75 = 64^\circ$).

Switch Adjustment

Note: Use the scale under the Red ST1 switch to field set the switches. The DMA incorporates two limit switches that limit the crank shaft from exceeding a set point if the zero or span potentiometer fails. The DMA also has an SPDT auxiliary switch. All switches can be adjusted anywhere over the 90° stroke.

ST1 Limit Switch (Red): This switch limits the minimum position at 0° or more. Set the switch at approx. 1° LESS than the Y Min. setpoint. The small set screw on the side of the red dial can be used for fine tuning adjustment.

ST2 Limit Switch (Yellow): This switch limits the maximum position at 90° or less. Set the switch at approx. 1° MORE than the Y Max. setpoint. The small set screw on the side of the yellow dial can be used for fine tuning adjustment.

MV Auxiliary Switch (Yellow): Set the switch to trip at the desired setpoint using the scale under the Red ST1 switch. When the motor is at 0°, the NC contact 4 and 3 opens, and the NO contact 4 and 2 closes.

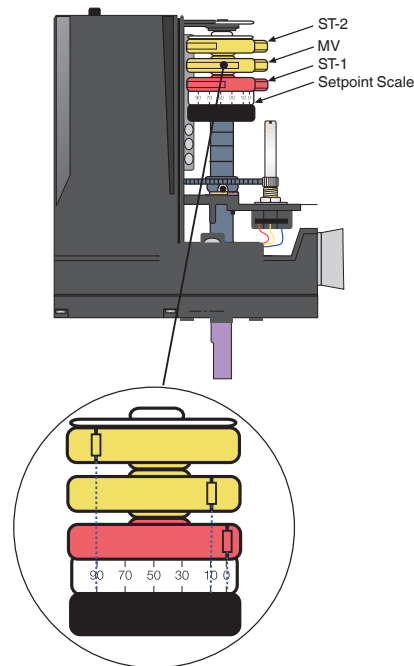

We reserve the right to make modifications in the course of technical development.



Karl Dungs, Inc.
3890 Pheasant Ridge Drive NE
Suite 150
Blaine, MN 55449, U.S.A.
Phone 763 582-1700
Fax 763 582-1799
e-mail info@karldungsusa.com
Internet <http://www.dungs.com/usa/>

Karl Dungs GmbH & Co. KG
P.O. Box 12 29
D-73602 Schorndorf, Germany
Phone +49 (0)7181-804-0
Fax +49 (0)7181-804-166
e-mail info@dungs.com
Internet <http://www.dungs.com>