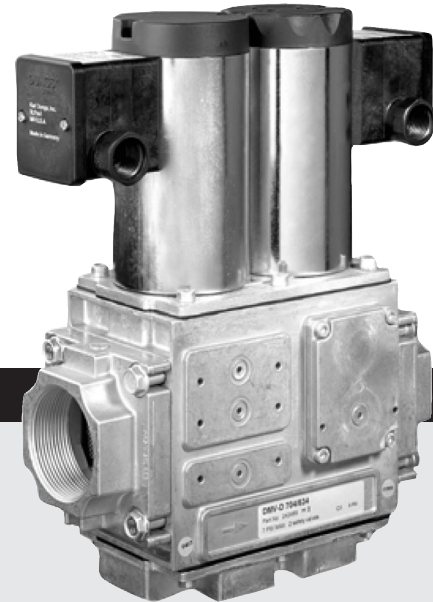

Table of Contents

Table of Contents	Page 1	Accessories & Replacement	Page 8
Approvals	Page 1		
Attention	Page 1		
Specification	Page 2		
Mounting	Page 3		
Painting Valve	Page 3		
Protection from Radiant Heat	Page 3		
Wiring	Page 4		
Valve Adjustment	Page 4		
Side Taps	Page 5		
Valve Leakage Test	Page 6		
Flow Curve	Page 7		
Pressure Drop for other Gases	Page 7		
Pulse Fired Applications	Page 8		
Multiple Burner Applications	Page 8		



Approvals



CSA:
 Certified File No.112901

Commonwealth of Massachusetts Approved Product Approval code G1-1107-35

Attention



The installation and maintenance of this product must be done under the supervision of an experienced and trained specialist. Never perform work if gas pressure or power is applied, or in the presence of an open flame.

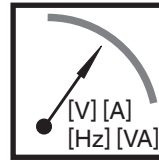

Check the ratings in the specifications to make sure that they are suitable for your application.



Please read the instruction before installing or operating. Keep the instruction in a safe place. You find the instruction also at www.dungs.com If these instructions are not heeded, the result may be personal injury or damage to property.



On completion of work on the safety valve, perform a leakage and function test.



Any adjustment and application-specific adjustment values must be made in accordance with the appliance-/boiler manufacturers instructions.



This product is intended for installations covered by, but not limited to, the following fuel gas codes and standards: NFPA 54, IFGC (International Fuel Gas Code), or CSA B149.1 (for Canada) or the following equipment codes and standards: CSD-1, NFPA 86, NFPA 37, ANSI Z83.4/CSA 3.7, ANSI Z83.18, ANSI Z21.13/CSA 4.9, or CSA B149.3 (for Canada).

Explanation of symbols

- 1, 2, 3 ... = Action
- = Instruction

Specification

DMV-D/604 Two normally closed automatic shutoff valves in one housing. V1 and V2 are fast opening, fast closing. Adjustable max. flow with V2.

DMV-DLE/604 Two normally closed automatic shutoff valves in one housing. V1 fast opening, fast closing. V2 is slow opening, fast closing. Adjustable max. flow and adjustable initial lift with V2.



Max. Operating Pressure
MOP = 7 PSI (500 mbar)
MOP = 5 PSI (360 mbar) CSA

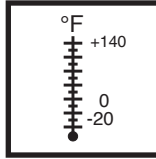

Ambient Temperature
-20 °F ... +140 °F
(-30 °C ... +60 °C)



Electrical Ratings
110 - 120 VAC / 50 - 60 Hz
Power Consumption with all coils energized
DMV-D(LE) 704: 90 VA

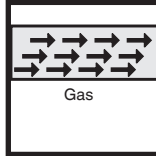

Gases

Dry, natural gas, propane, butane; other noncorrosive gases. A "dry" gas has a dew point lower than +15 °F and its relative humidity is less than 60 %.

Materials in contact with Gas

Housing: Aluminium, Steel, free of nonferrous metals. Sealings on valve seats: NBR-based rubber.

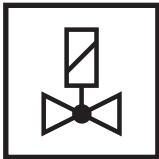

Classification of Valve V1 and V2

Safety Shutoff Valve:
ANSI Z21.21 • CSA 6.5 C/I Valves

Closing Time

< 1 s

Opening Time

DMV-D: V1 & V2 < 1 s

DMV-DLE: V1 < 1 s

V2 10 to 20 s

Max. Flow Setting (DMV-D & DMV-DLE)

Adjustable on V2:
<10 to 100 % of total flow

Initial Lift Adjustment (DMV-DLE) only

Adjustable on V2:
0 to 70 % of total flow; 0 to 35 % of stroke

Power Consumption with all coils energized

DMV-D(LE) 704: 90 VA

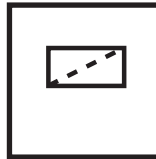

Strainer

23 Mesh, installed in the housing upstream V1

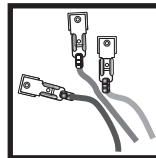

Electrical Connection

Screw terminals with 1/2" NPT conduit connection

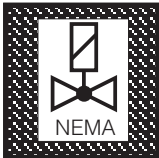

Enclosure Rating

NEMA Type 4x

Mounting

Setup

1. Examine the DMV valve for shipping damage.
2. The main gas supply must be shutoff before starting the installation.
3. The inside of the DMV valve, the flanges, and piping must be clean and free of dirt. Remove all dirt and debris before installing the DMV valve. Failure to remove dirt / debris could result in valve damage or improper performance.

Recommended Procedure to Mount the Flanges

1. Unpack the DMV valve and remove the bolts by using 13 mm wrench.
2. Remove the two protective covers.
3. Verify the o-rings and the grooves are clean and in good condition.
4. Install the DMV valve with the gas flow matching the direction indicated by the arrows on the casting.
5. Mount the DMV solenoid valve from vertically upright to horizontal.
6. Clean the mounting surface of the flanges.
7. Mount the flanges to the DMV valve.
8. Tighten the screws in a crisscross pattern. See table for recommended torque!

Installation position

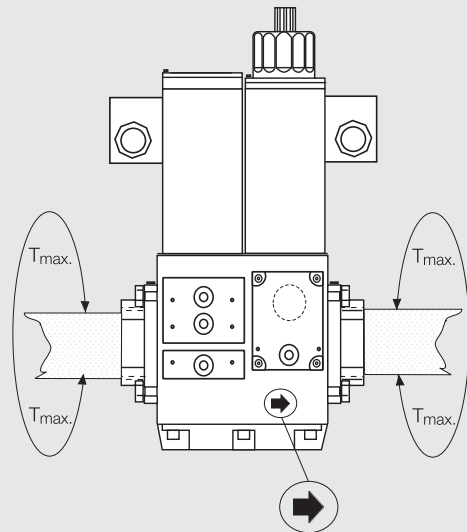
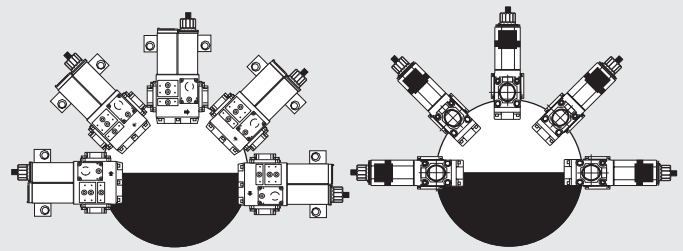

If the flow is not in the same direction of the arrows, the valves will not operate properly.

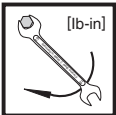

Recommended Torque System Accessories

M8

Screw Size

134 lb-in

[lb-in]

Recommended Piping Procedure

- Use new, properly reamed and threaded pipe.
- Apply good quality pipe sealant, putting a moderate amount on the male threads only. If pipe sealant lodges on the valve seat, it will prevent proper operation. If using LP gas, use pipe sealant rated for use with LP gas.

- Do not thread pipe too far. Valve distortion and/or malfunction may result from excess pipe in the valve body.
- Apply counter pressure only a parallel jaw wrench only to the flats on the flange when connecting to pipe.
- Do not overtighten the pipe. Follow the maximum torque values listed below.

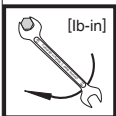

Recommended Torque for Piping

2"

NPT pipe

1190

[lb-in]

- On completion of work on the DMV valve, perform a leakage test. (See "Valve Leakage Test")

Painting Valve

- It is not recommended that this valve be painted. Painting covers date codes and other labels that identify this valve.
- If the valve needs to be painted, a paint free of volatile organic components (VOC's) must be used. VOC's can damage

- valve o-rings, resulting in external gas leakage over time.
- During the painting process, use measures that will allow the valve's date code and other labeling information to be legible after the paint is dry

Protection from Radiant Heat

- Radiant heat must be considered as a heat source that could result in an ambient temperature higher than the rating of this valve.

- Provide proper shielding to protect against radiant heat.

Wiring

- Remove the junction box cover to expose the three terminals
- The coil can be rotated to accommodate a conduit connection in any position.
- Use only one of the knock-outs for connecting conduit to the junction box. Support the opposite side of the junction box when removing the knock-out.

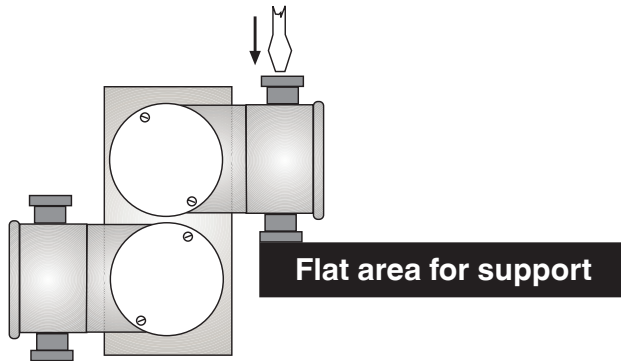

- Use appropriate tools to connect the conduit fitting to the junction box.
- Make electrical connections to the terminals using the wiring diagram.

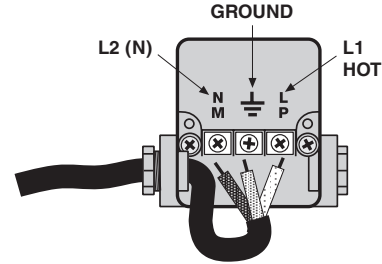

- Replace junction box cover.

- Run 14 or 16 gauge wire rated for 95 °C (200 °F) through the conduit and attach 1/2" NPT conduit to the junction box.



All wiring must comply with local electrical codes, ordinances and regulations.

Valve Adjustment

Flow Setting

1. The valve is factory set with the flow adjustment fully open.
2. Locate the flow adjustment on top of valve 2. There are two screws, the holding screw is recessed and has a blue sealing compound on it, while the pan head screw protrudes from the cap. Loosen the pan head screw until you can freely rotate the flow adjustment. Turn clockwise for less gas or counterclockwise for more gas. Check the flow at the burner with an orifice or flow meter.
3. Tighten the pan head screw on the adjustment cap.

Initial Lift Adjustment (DMV-DLE only)

The initial lift adjustment varies the initial gas flow through the valves as the valve seat begins to open. This adjustment can vary the initial flow between 0 % and 70 % of the total gas flow; 0 to 35 % of stroke. All DMV-DLE valves are factory set with no initial lift. To adjust the lift proceed as follows:

4. Unscrew the small black cap on top of the silver hydraulic brake to expose the initial lift adjustment knob.
5. The black cap also serves as tool. Turn the cap over and insert it on the slot on the adjustment knob.
6. Turn the knob clockwise for a minimum initial lift or counterclockwise for a maximum initial lift.
7. Once the desired initial fast lift has been achieved, reinstall the black cap.

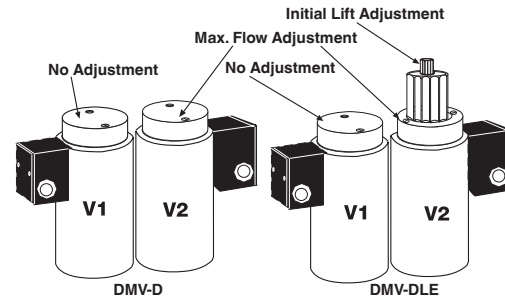

Initial Lift Opening Curve

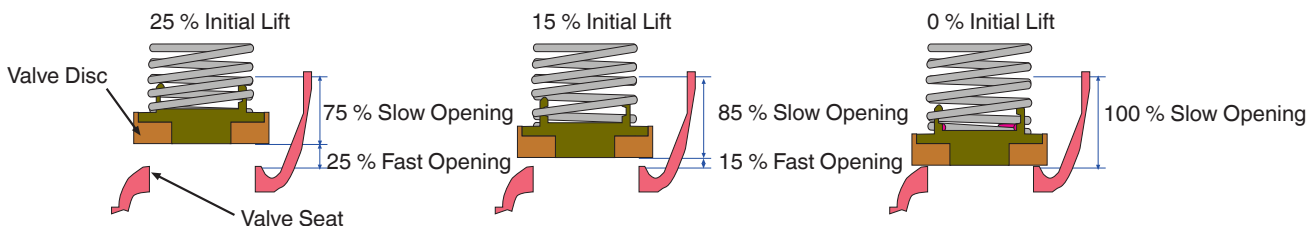
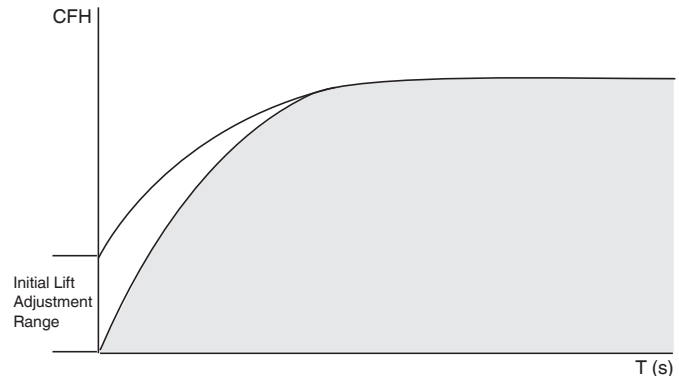

Side Taps

DMV 704/604 Side Taps

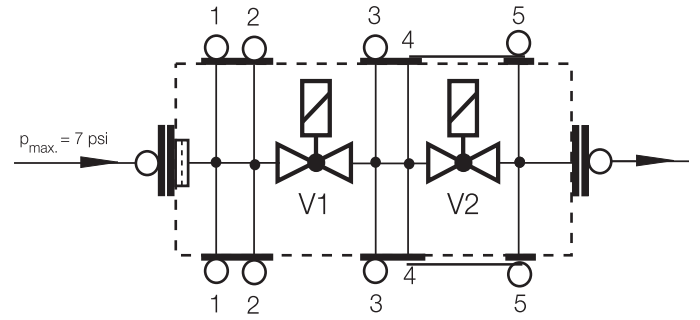
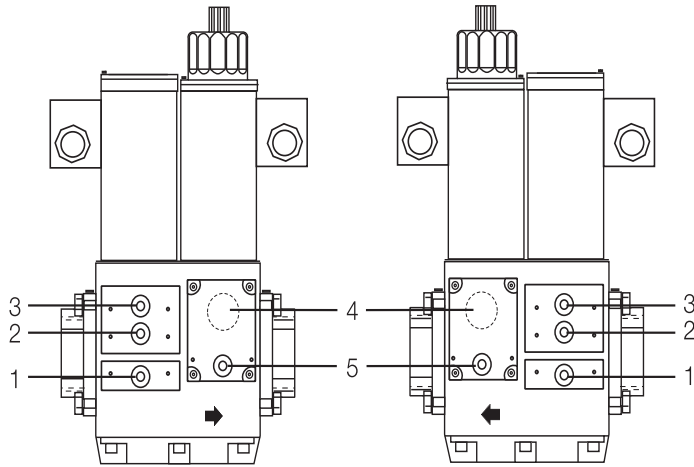

Valve Leakage Test

This leak test procedure tests the external sealing and valve seat sealing capabilities of the DMV automatic safety shutoff valve. Only qualified personnel should perform this test.

It is required that this test be done on the initial system startup, and then repeated at least annually. Possibly more often depending on the application, environmental parameters, and the requirements of the authority having jurisdiction.

Setup

This test requires the following:

- A) Test nipples installed in the downstream pressure tap port of each automatic safety shutoff valve to make the required 1/4" hose connection in step 4.
- B) A transparent glass of water filled at least 1 inch from the bottom.
- C) A proper leak test tube. An aluminum or copper 1/4" rigid tube with a 45° cut at the end that is then connected to a 1/4" flexible hose of some convenient length provides for a more accurate leakage measurement. However, a 45° cut at the end of the 1/4" flexible hose will suffice, but it will not likely be as accurate as the rigid tube.
- D) For detecting external leakages, an all purpose liquid leak detector solution is required.

Leak Test Procedure

Use the illustration below as a reference.

1. With the upstream ball valve open, the downstream ball valve closed and both valves energized, apply an all purpose liquid leak detector solution to the "External Leakage Test Areas" indicated in the illustration below, to any accessories mounted to the safety valve, and to all gas piping and gas components downstream the equipment isolation valve, and the inlet and outlet gas piping of the automatic safety shutoff valve. The presence of bubbles

indicates a leak, which needs to be rectified before proceeding.

2. Then, de-energize the burner system and verify that both automatic safety shutoff valves are closed.
3. Close the upstream and downstream manual ball valve.
4. Using a screwdriver, slowly open the V1 test nipple (port 3 or 4) by turning it counter clockwise to depressurize the volume between the two valves, and connect the 1/4" flexible hose to the test nipple.
5. Slowly open the upstream manual ball valve, and then provide for some time to allow potential leakage to charge the test chamber before measuring the valve seat leakage.
6. Immerse the 1/4 in. tube vertically 1/2 in. (12.7 mm) below the water surface. If bubbles emerge from the 1/4" tube and after the leakage rate has stabilized, count the number of bubbles appearing during a 10 second period. (See chart below for allowable leakage rates.)
7. Repeat the same procedure for valve V2 (port 5), except that valve #1 needs to be opened.

After completing the above tests proceed as follows:

8. Verify that the downstream manual ball valve is closed, and both automatic safety shutoff valves are de-energized.
9. Remove the flexible hose, and close all test nipples.
10. With the upstream manual ball valve open, energize both automatic safety shutoff valves.
11. Use soapy water to leak test all test nipples to ensure that there are no leaks.
12. If no leakage is detected, de-energize all automatic safety shutoff valves, and open the downstream manual ball valve.



If leakage values are exceeded, replace valve immediately.

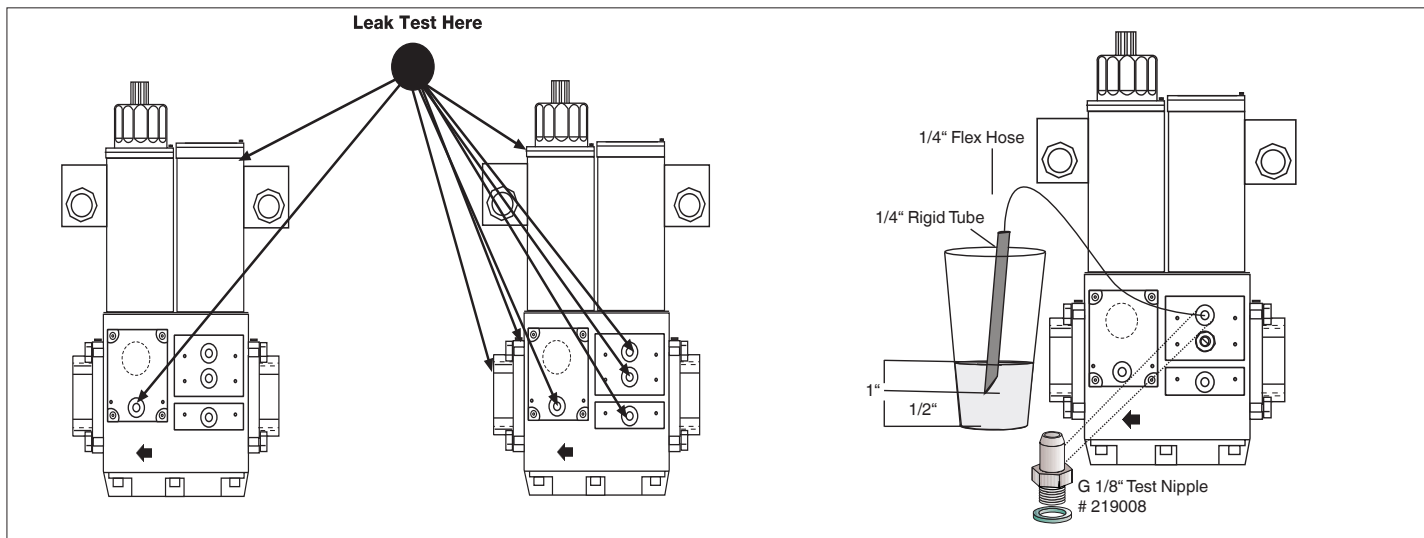

Type	Allowable Valve Seat Leakage* up to 7 PSI inlet	# of Bubbles in 10 s		
		Air	Natural Gas	LP
DMV-D(LE) 704/604	628 cc/hr	12	15	9

*Based on air and test conditions per UL 429 Section 29. (Air or inert gas at a pressure of 1/4 psig and also at a pressure of one and one-half times maximum operating pressure differential, but not less than 1/2 psig. This test shall be applied with the valve installed in its intended position.) Volume of bubble defined in Table 2 of FCI 70-2-1998.

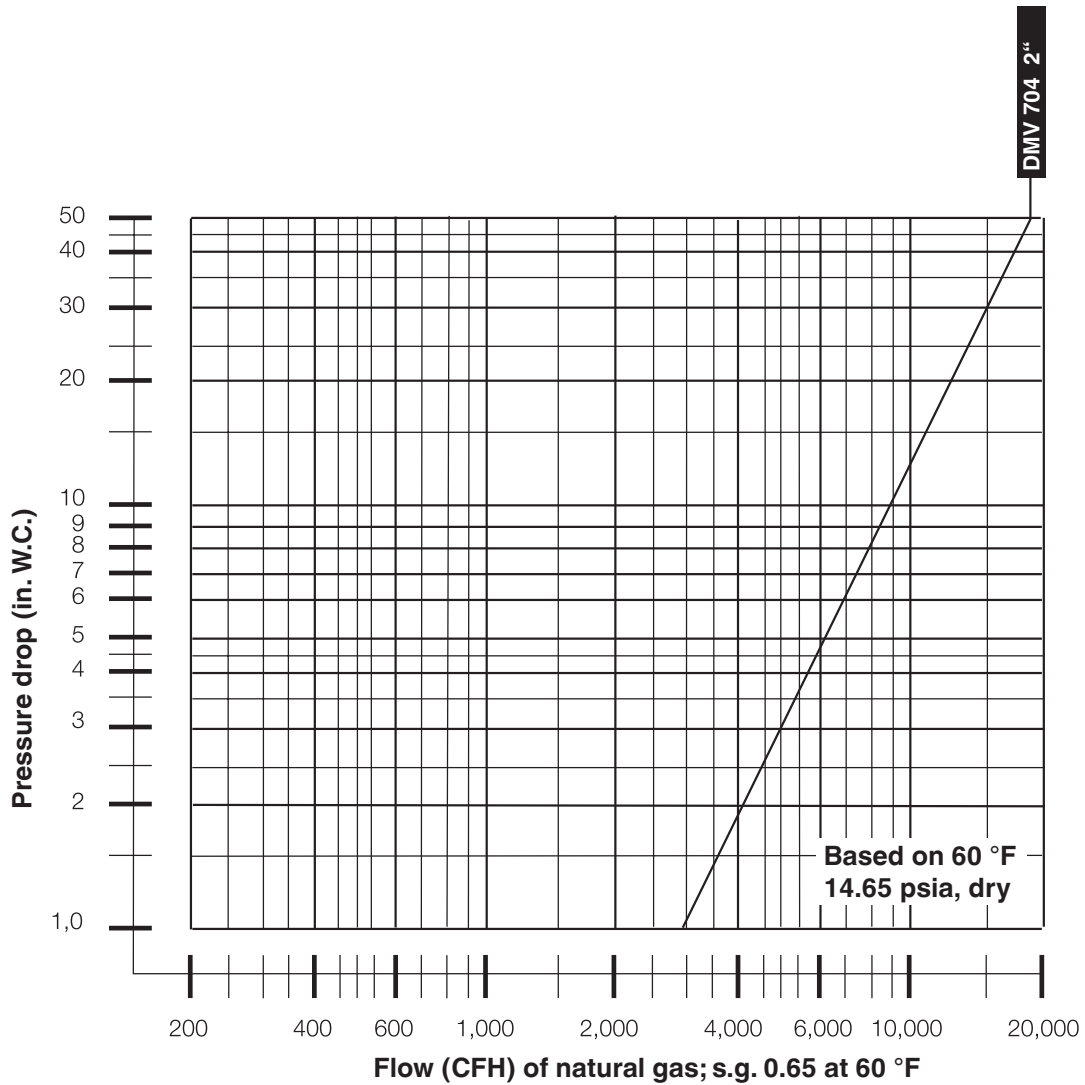

Pressure Drop for other Gases

To determine the pressure drop when using a gas other than natural gas, use the flow formula below and f value located in the table below to determine the "corrected" flow rate in CFH through the valve for the other gas used. For example,

when using propane, divide the volume (CFH) of propane required for the application by the calculated value f (f = 0.66 for propane). Use this "corrected" flow rate and the flow curve on the next page to determine pressure drop for propane.

Determining equivalent flow through valves using another gas

$$\dot{V}_{\text{gas used}} = \dot{V}_{\text{Natural gas}} \times f$$

$$f = \sqrt{\frac{\text{Density of Natural gas}}{\text{Density of gas used}}}$$

Type of gas	Density [kg/m ³]	s.g.	f
Natural gas	0.81	0.65	1.00
Butane	2.39	1.95	0.58
Propane	1.86	1.50	0.66
Air	1.24	1.00	0.80

Pulse Fired Applications

When using these valves on pulse fired applications, the following apply:

- Before installing the valve, the inside of all gas piping upstream to the nearest filter shall be cleaned and that filter shall have an insert with mesh no larger than 50 micron.
- The valve shall be installed in the upright position.
- The valve shall be applied within all of its ratings. The type of gas, the ambient temperature and the cycle rate of the valve are critical.
- The valve shall be leak tested at least annually.
- After the cycle life has been exceeded, the valve shall be immediately replaced.

Multiple Burner Applications

On multiple burner applications, the following requirements apply:

- A manually operated shutoff valve shall be installed downstream of each individual burner safety shutoff valve.
- The backpressure on the individual burner safety shutoff valve shall be measured during the commissioning of

the furnace to verify that while the all other burners are firing and the individual burner safety shutoff valve shall is deenergized, the backpressure does not exceed 2 PSI. Measuring the backpressure shall also be repeated during purge and post purge. A pressure gauge can be used to measure the backpressure.

Accessories & Replacement

Accessories/Adapter	Order No.	
Visual Indicator	266949	The indicator mounts to the bottom of the valve and visually displays when the valve is open or closed.
CPI 400 valve switch	266968	Valve switch with visual indication.
DMV-D(LE) 704 gasket for flange	231574	
2" NPT Flange	232407	
2" Rp Flange	215384	
120 VAC Replacement Coil (Mag. Type 201)	246517	
Vent Line Adapter - 1" NPT (field mountable)	243760	
G 1/8" Test nipple with gasket	219008	
Hydraulic Brake	224977	
Main flow adjustment knob	231790	



Karl Dungs, Inc.
3890 Pheasant Ridge Drive NE
Suite 150
Blaine, MN 55449, U.S.A.
Phone 763 582-1700
Fax 763 582-1799
e-mail info@karldungsusa.com
Internet <http://www.dungs.com/usa/>

Karl Dungs GmbH & Co. KG
P.O. Box 12 29
D-73602 Schorndorf, Germany
Phone +49 (0)7181-804-0
Fax +49 (0)7181-804-166
e-mail info@dungs.com
Internet <http://www.dungs.com>