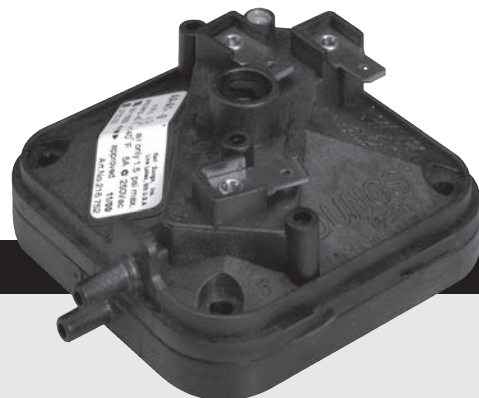

**Table of Contents**

Table of Contents ..... Page 1  
 Approvals ..... Page 1  
 Attention ..... Page 1  
 Specifications ..... Page 2  
 Models Designations & Ranges ..... Page 2  
 Operation ..... Page 3  
 Pressure Connection ..... Page 3  
 Application & Connection Examples ..... Page 3  
 Installation Position ..... Page 4  
 Wiring ..... Page 4  
 Operation & Adjustment ..... Page 5  
 Maintenance & Testing ..... Page 5  
 Accessories & Replacement ..... Page 5



**Approvals**



UL Recognized: UL 353  
 File # MH16628



CSA Certified: CSA C22.2 No. 14  
 File # 201527



FM Approved: Class 3510, 3530  
 File # J.I. 1T7A8.AF

Commonwealth of Massachusetts Approved Product Approval code G3-0106-191

**Attention**



The installation and maintenance of this product must be done under the supervision of an experienced and trained specialist. Never perform work if gas pressure or power is applied, or in the presence of an open flame.



Check the ratings in the specifications to verify that they are suitable for your application.



Please read the instruction before installing or operating. Keep the instruction in a safe place. You find the instruction also at [www.dungs.com](http://www.dungs.com). If these instructions are not heeded, the result may be personal injury or damage to property.



On completion of work on the pressure switch, perform a leakage and function test.



Any adjustment and application-specific adjustment values must be made in accordance with the equipment manufacturers instructions.



This product is intended for installations covered by, but not limited to, the following codes and standards: NFPA 86, ANSI Z83.4/CSA 3.7, ANSI Z83.18/CSA 4.9, ANSI Z21.13, CSD-1, UL 795, CSA B149.1 or CSA B149.3

**Explanation of symbols**

- 1, 2, 3 ... = Action
- = Instruction

## Specifications

AA...A1

SPDT differential pressure switch in pressure and vacuum ranges. The differential pressure acts via the diaphragm against the force of the setting spring on the micro-switch. The pressure switch operates without any auxiliary power.

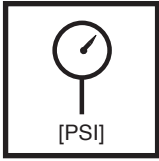

**Max. Operating Pressure**  
MOP = 1.5 PSI (103 mbar)

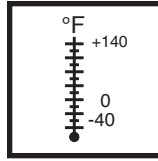

**Ambient / Medium Temperature**  
-40 °F ... +140 °F  
(-40 °C ... +60 °C)



**Electrical Connection**  
1/4 x 1/32" (6.3 x 0.8 mm)  
flat male terminals

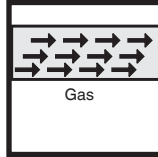

**Gases**

Air and non-aggressive gases.  
**Not** suitable for natural gas, propane, butane and other combustible gases.

**Materials in contact with Gas**

Housing: Polycarbonate  
Switch: Polycarbonate  
Diaphragm: NBR-based rubber  
Switching contact: Silver (Ag)

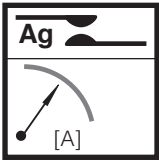

**Contact Rating**  
5 A resistive,  
3 A inductive @ 120 VAC  
1 A @ 12 - 48 VDC

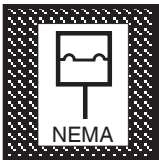

**Enclosure**  
NEMA Type 1 / NEMA Type 12 with appropriate cover

## Models Designations & Ranges

Type	Version	Description	Order No.	Factory setting range in. W.C.	Switching hysteresis in. W.C.
AA-A1-0-...	AA-A1-0-2	No cover	266906	0.16 - 1.20	≤ 0.14
	AA-A1-0-3	No cover	266904	0.40 - 4.00	≤ 0.20
	AA-A1-0-4	No cover	266908	1.00 - 20.00	≤ 0.40
AA-A1-3-...	AA-A1-3-2	Includes NEMA Type 12 cover and 1/2 NPT conduit connection	266907	0.16 - 1.20	≤ 0.14
	AA-A1-3-3	Includes NEMA Type 12 cover and 1/2 NPT conduit connection	266905	0.40 - 4.00	≤ 0.20
	AA-A1-3-4	Includes NEMA Type 12 cover and 1/2 NPT conduit connection	266909	1.00 - 20.00	≤ 0.40

## Operation

### Definition of switching hysteresis $\Delta p$

The pressure difference between the upper and lower switching pressures.

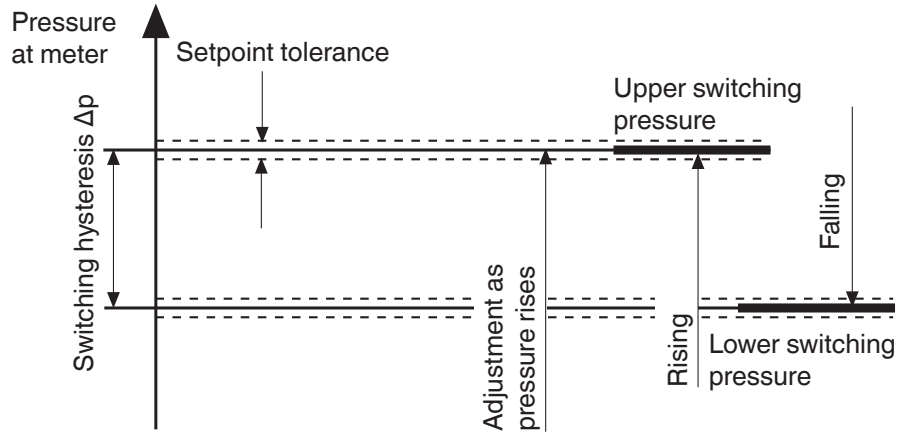

## Pressure Connection

Connection p2 (-) = lower pressure  
Connection p1 (+) = higher pressure

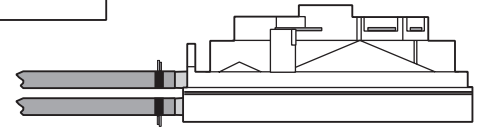
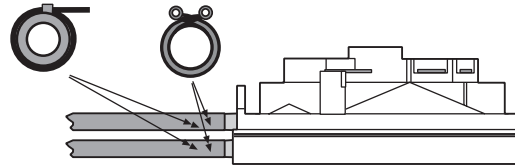
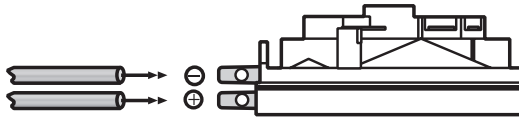

### AA...A1 Mounting Procedure

- Use suitable hoses for the medium.
- Use a maximum 5/32" ID hose
- Secure the hoses with a cable tie or a cable clip.

## Application & Connection Examples

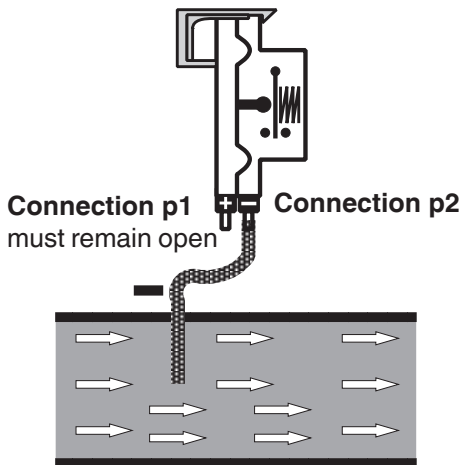

### System vacuum monitor

AA...A1 is connected to the air duct with the p2 (-) connection. p1 (+) is not connected with the air duct.

Do not seal the p1 (+) connection; it must be open to the atmosphere.

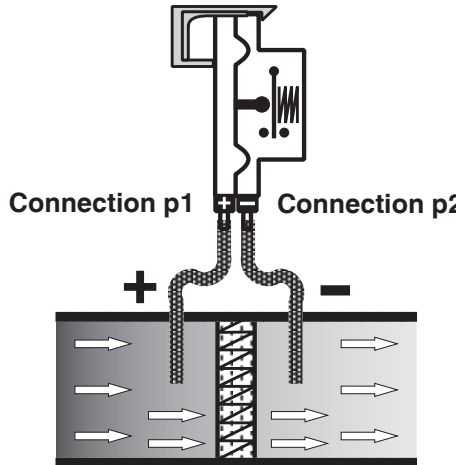

### Filter monitoring

To monitor a filter, the AA...A1 can be connected as shown above.

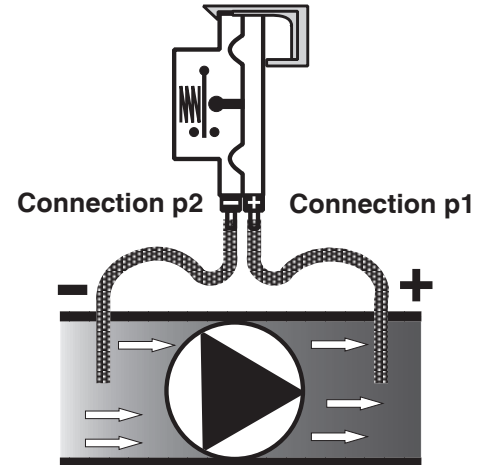

### Blower monitoring

For blower monitoring, connect connection p1 (+) to the air duct on the downstream side of the blower and connection p2 (-) to the air duct upstream of the blower.

**⚠ Prevent dirt from entering into the device through connection p1(+)**

# Installation Position

Standard installation position is **vertical** upright diaphragm.  
 When installed **horizontally**, the pressure switch switches at a pressure higher by approx. 0.2 in. W.C. When installed **upside down**, the pressure switch switches at a pressure lower by approx. 0.2 in. W.C. When installed in **other positions**, the pressure switch switches at pressure deviating from the set reference value by max.  $\pm 0.2$  in. W.C.

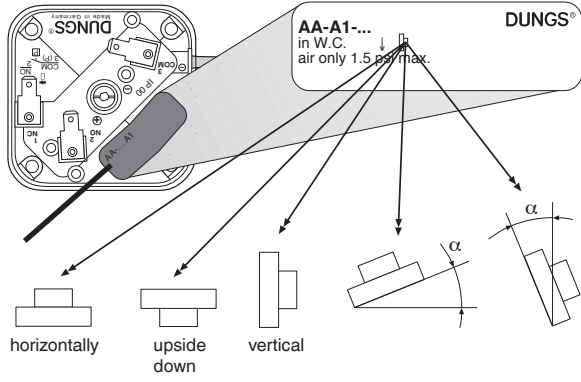

Refer to Label!

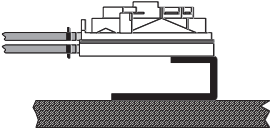

**Ensure that the pressure switch is installed free of vibration!**

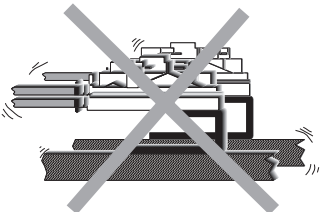

# Wiring

- If applicable, remove the clear cover from the switch.
- Use 14 or 16 AWG wire rated for at least 75 °C.
- Connect the wiring to the appropriate 1/4 x 1/32" (6.3 x 0.8 mm) flat male terminals.

**All wiring must comply with local electrical codes, ordinances and regulations.**

**Do not exceed the switch ratings given in the specifications and on the switch.**

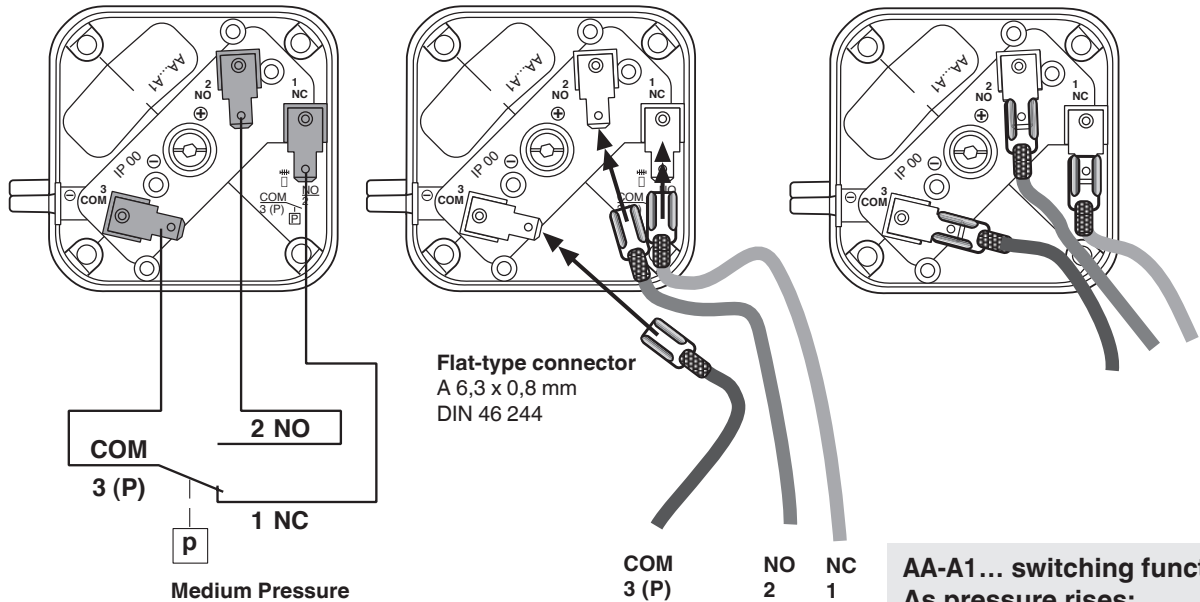

**AA-A1... switching function**  
**As pressure rises:**  
 1 NC opens, 2 NO closes  
**As pressure falls:**  
 1 NC closes, 2 NO opens

**Operation & Adjustment**

**Adjusting the Set Point**

- Do NOT attempt to adjust the factory setting of the switch. Breaking the seal affects the switches ability to act as a differential switch.

**Automatic Reset**

- The NC contact of the AA...A1 breaks when pressure rises above the set point. It makes automatically when pressure falls below set point.

**Maintenance & Testing**

**Annually check the switch for proper operation Set Point Calibration**

1. Connect a meter capable of reading +/- 0.1 ohms to the NC and COM contacts.
2. Measure the resistance across the NC and COM contacts. If the resistance is more than 1.0 ohm, the switch switch should be replaced, since this indicates that the switch contacts are starting to either corrode or carbonizing.

3. Apply pressure to the + air pressure connection, and confirm that the NC contact breaks when pressure rises above the set point and that the NO contact makes. The NC contact will make automatically when pressure falls below the set point pressure.
4. Connect a meter capable or reading +/- 0.1 ohms to the NO and COM contacts.
5. Measure the resistance across the NO and COM contacts. If the resistance is more than 1.0 ohm, the switch switch should be replaced, since this indicates that the switch contacts are starting to either corrode or carbonizing.

**Accessories & Replacement**

Accessory for pressure switch	Order No.
Mounting plate (flat plastic)	230301
NEMA Type 1 Cover (1pcs)	230216
NEMA Type 1 Cover (77 pcs)	231432
NEMA Type 2 Cover (1pcs)	230280
NEMA Type 2 Cover (200 pcs)	250107
NEMA Type 12 cover with 1/2 NPT conduit connection	225816

We reserve the right to make modifications in the course of technical development.



**Karl Dungs, Inc.**  
3890 Pheasant Ridge Drive NE  
Suite 150  
Blaine, MN 55449, U.S.A.  
Phone 763 582-1700  
Fax 763 582-1799  
e-mail [info@karldungsusa.com](mailto:info@karldungsusa.com)  
Internet <http://www.dungs.com/usa/>

**Karl Dungs GmbH & Co. KG**  
P.O. Box 12 29  
D-73602 Schorndorf, Germany  
Phone +49 (0)7181-804-0  
Fax +49 (0)7181-804-166  
e-mail [info@dungs.com](mailto:info@dungs.com)  
Internet <http://www.dungs.com>