



FEDERAL SIGNAL CORPORATION'S

MODELS

2-120

2-240

Outdoor Warning Sirens

**INSTALLATION, OPERATION & SERVICE
MANUAL**

Copyright 2006 Federal Signal Corporation

255154R
07/13

IMPORTANT NOTICE

Federal Signal reserves the right to make changes to devices and specifications detailed in the manual at any time in order to improve reliability, function or design. The information in this book has been carefully checked and is believed to be accurate; however, no responsibility is assumed for any inaccuracies.

SAFETY NOTICES

People's lives depend on your selection of suitable equipment and installation sites and your safe installation, service, and operation of our products. Federal Signal recommends the following publications from the Federal Emergency Management Agency for assistance with planning an outdoor warning system: 1. The "Outdoor Warning Guide" (CPG 1-17), 2. "Civil Preparedness, Principles of Warning" (CPG 1-14), 3. FEMA-REP-1, Appendix 3 (Nuclear Plant Guideline), 4. FEMA-REP-10 (Nuclear Plant Guideline), 5. Occupational Safety and Health Administration (OSHA), 6. National Institute for Occupational Safety and Health (NIOSH), and 7. National Fire Protection Association (NFPA) guidelines as applicable.. Contact Alerting and Notification System's Customer Care Center at: <http://www.alertnotification.com> or 1-800-524-3021 for further information about these publications.

It is important to read, understand and follow all instructions shipped with this product. In addition, listed below are some other important safety instructions and precautions you should follow.

PLANNING

- If suitable warning equipment is not selected, the installation site for the siren is not selected properly or the siren is not installed properly, it may not produce the intended optimum audible warning. Follow Federal Emergency Management Agency (FEMA) recommendations.
- If sirens are not activated in a timely manner when an emergency condition exists, they cannot provide the intended audible warning. It is imperative that knowledgeable people, who are provided with the necessary information, are available at all times to authorize the activation of the sirens.
- When sirens are used out of doors, people indoors may not be able to hear the warning signals. Separate warning devices or procedures may be needed to effectively warn people indoors.
- The sound output of sirens is capable of causing permanent hearing damage. To prevent excessive exposure, carefully plan siren placement, post warnings, and restrict access to areas near sirens.
- Activating the sirens may not result in people taking the desired actions if those to be warned are not properly trained about the meaning of siren sounds. Siren users should follow FEMA recommendations and instruct those to be warned of correct actions to be taken.
- A siren that doesn't work won't provide any warning. After installation, service, or maintenance, test the siren system to confirm that it is operating properly. Test the system regularly to confirm that it will be operational in an emergency.
- If future service and operating personnel do not have these instructions to refer to, the siren system may not provide the intended audible warning and service personnel may be exposed to death, permanent hearing loss, or other bodily injury. File these instructions in a safe place and refer to them periodically. Give a copy of these instructions to new recruits and trainees. Also give a copy to anyone who is going to service or repair the siren.

SAFETY NOTICES

People's lives depend on your safe installation, service and operation of our products. It is important to read, understand and follow all instructions shipped with this product. In addition, listed below are some other important safety instructions and precautions you should follow:

INSTALLATION & SERVICE

- Electrocutation or severe personal injury can occur when performing various installation and service functions such as making electrical connections, drilling holes, or lifting equipment. Therefore experienced electricians in accordance with national, state and any other electrical codes having jurisdiction should perform installation. All work should be performed under the direction of the installation or service crew safety foreman.
- The sound output of sirens is capable of causing permanent hearing damage. To prevent excessive exposure, carefully plan siren placement, post warnings and restrict access to areas near the sirens. Sirens may be operated from remote control points. Whenever possible, disconnect all siren power including batteries before working near the siren.
- After installation or service, test the siren system to confirm that it is operating properly. Test the system regularly to confirm that it will be operational in an emergency.
- If future service personnel do not have these warnings and all other instructions shipped with the equipment to refer to, the siren system may not provide the intended audible warning and service personnel may be exposed to death, permanent hearing loss, or other bodily injury. File these instructions in a safe place and refer to them periodically. Give a copy of these instructions to new recruits and trainees. Also, give a copy to anyone who is going to service or repair the sirens. For additional copies, call the Federal Warning Systems Customer Care Center at 800-524-3021 or write to them at 2645 Federal Signal Drive, University Park, IL 60484-3167.

OPERATION

- Failure to understand the capabilities and limitations of your siren system could result in permanent hearing loss, other serious injuries or death to persons too close to the sirens when you activate them or to those you need to warn. Carefully read and thoroughly understand all safety notices in this manual and all operations-related-items in all instruction manuals shipped with equipment. Thoroughly discuss all contingency plans with those responsible for warning people in your community, company, or jurisdiction.

Limited Warranty

*The Alerting and Notification Systems Division of **Federal Signal Corporation (Federal)** warrants each new product to be free from defects in material and workmanship, under normal use and service, for a period of two years on parts replacement and factory-performed labor (one year for Informer, and Federal software products) from the date of delivery to the first user-purchaser. Federal warrants every 2001, Eclipse and 508 Siren (Top of pole only) to be free from defects in material, per our standard warranty, under normal use and service for a period of five years on parts replacement.*

During this warranty period, the obligation of Federal is limited to repairing or replacing, as Federal may elect, any part or parts of such product which after examination by Federal, are determined to be defective in material and/or workmanship.

Federal will provide warranty for any unit which is delivered, transported prepaid, to the Federal factory or designated authorized warranty service center for examination and such examination reveals a defect in material and/or workmanship.

This warranty does not cover travel expenses, the cost of specialized equipment for gaining access to the product, or labor charges for removal and re-installation of the product. The Federal Signal Corporation warranty shall not apply to components or accessories that have a separate warranty by the original manufacturer, such as, but not limited to batteries.

Federal will provide on-site warranty service during the first 60-days after the completion of the installation, when Federal has provided a turn-key installation including optimization and/or commissioning services.

This warranty does not extend to any unit which has been subjected to abuse, misuse, improper installation or which has been inadequately maintained, nor to units which have problems related to service or modification at any facility other than Federal factory or authorized warranty service centers. Moreover, Federal shall have no liability with respect to defects arising in Products through any cause other than ordinary use (such as, for example, accident, fire, lightning, water damage, or other remaining acts of God).

THERE ARE NO OTHER WARRANTIES, EXPRESSED OR IMPLIED, INCLUDING BUT NOT LIMITED TO, ANY IMPLIED WARRANTIES OF MERCHANTABILITY OR FITNESS FOR A PARTICULAR PURPOSE. IN NO EVENT SHALL FEDERAL BE LIABLE FOR ANY LOSS OF PROFITS OR ANY INDIRECT OR CONSEQUENTIAL DAMAGES ARISING OUT OF ANY SUCH DEFECT IN MATERIAL WORKMANSHIP.



Advancing security and well-being.

2645 Federal Signal Drive, University Park, IL 60484
Phone: 800.524.3021 Fax: 708.534.4865
www.alertnotification.com

WARNING

Read and understand the information contained in this manual, before attempting to install or service the siren.

Pay careful attention to the following notices located on the equipment.

NOTICES - EXTERNALLY PLACED

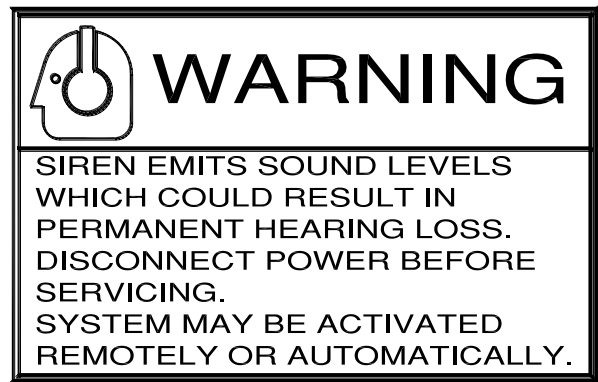

TABLE OF CONTENTS

<u>Paragraph</u>		<u>Page</u>
	SECTION I - GENERAL DESCRIPTION	
1-1	Scope of This Manual	1
1-2	General.....	1
1-3	Siren Description	1
1-4	Mechanical Description	1
1-5	Control Description.....	2
1-6	Signal Description.....	3
	SECTION II - SPECIFICATIONS	
2-1	Model 2.....	4
	SECTION III - INSTALLATION	
3-1	Siren Location.....	5
3-2	Physical Installation.....	6
3-3	Electrical Connections	11
3-4	Preoperation Checks	12
	SECTION IV - CIRCUIT DESCRIPTION	
4-1	Siren Control Description	13
	SECTION V - SERVICE AND MAINTENANCE	
5-1.	General.....	14
5-1.A	Minimum Recommended Inspection	14
5-1.B	Annual Inspection	14
5-2	Corrective Maintenance	15

SECTION I

CHARACTERISTICS

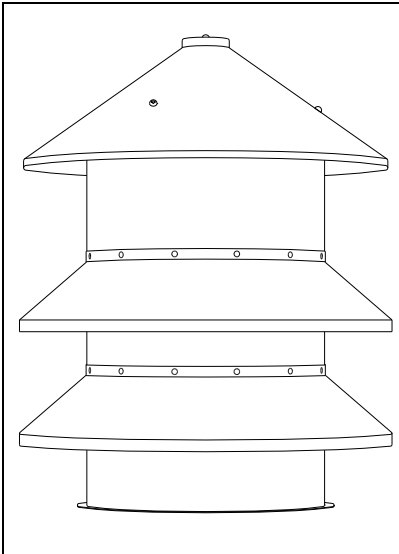

Figure 1-1. Model 2 Siren

1-1. SCOPE OF THIS MANUAL

This service manual describes the characteristics, specifications, installation, controls, theory of operation and servicing of the Federal Signal Model 2 Outdoor Warning Siren.

1.2. GENERAL

The Federal Signal Model 2 Outdoor Warning Sirens are omni-directional sirens that are capable of producing high intensity warning signals over a large area. Federal Signal provides mounting hardware that enables the user to install a siren on a utility pole or on the roof of a building. As a result, the siren can be installed in almost any situation. The high efficiency of these siren models enables them to produce a high sound level while making moderate demands on the power source.

1-3. SIREN DESCRIPTION

The Model 2 Siren (Figure 1-1) is a 102dB single tone siren.

The Model 2 siren mechanism is enclosed in a sheet metal housing. A conical dome is mounted on the top of the housing and two truncated conical cowls are attached to the housing, approximately one-third and two-thirds along the height of the housing.

A Model RC2W Motor Starter is required to operate the siren. The Model 2 uses a 120 or 240 volt universal motor that can operate from either dc or 25-60Hz single-phase AC.

1.4. MECHANICAL DESCRIPTION

The mechanism of all siren models covered in this manual consists of a vertically installed motor with a stator attached to the motor housing, and a rotor mounted on the drive-shaft concentric to the stator. The rotor and

stator each contain at least one row of ports. As the motor rotates the rotor, air is drawn through an intake tube, and passes through the rotor and stator ports in pulses. These pulses are produced because the rotor alternately opens and closes the stator ports. The pulses of air produce sound at a frequency (pitch) that is dependent on the instantaneous rotational speed of the motor, and the number of ports in the rotor-stator combination.

A Model RC2W Motor Starter is required to operate the siren. The Model 2 uses a 120 or 240 volt universal motor that can operate from either dc or 25-60Hz single-phase AC.

1-5. CONTROL DESCRIPTION

A. Models RC2W-120 (120VAC), AND RC2W-240 (240VAC)

The Model RC2W Motor Starters are basically a heavy-duty relay that is required for the starting and operating current of a Model 2 siren. The RC2W is enclosed in a NEMA type 3R enclosure. The unit must be installed on a vertical surface.

B. Models FC (1-way status), or FCTB (2-way status) Controllers

The *FC*, or *FCTB* siren control units provide RF and/or wire line control of individually programmable timing cycles for contact closure outputs. The versatility of the *FC* makes it an ideal choice for virtually all siren control applications or any other process that can be controlled via relay contacts.

The microprocessor based controller contains the following features:

- *Synthesized Radio Receiver (Low Band, High Band, or UHF - 3 separate models)*
- *Two-Tone and DTMF Decoders*
- *Up to 4 Individually Programmable Output Relays*
- *Siren Tone Generator*
- *Push Buttons for Local Control*
- *Contact Closure Inputs for Land Line Control*
- *RS232 Programming Port*
- *Diagnostic LED's*
- *Programmability*

All functions of the *FC* controller are programmable from a current WINDOWS compatible computer with an RS232 port using Federal Signal's easy to use *FSPWARE* programming software. The software allows easy configuration, uploading and downloading of control programs.

Programming options include:

- *Radio Receiver Frequency*
- *Single and Two-Tone Sequential Decode Tones & Tone Lengths*
- *DTMF Decode Digits*
- *Output Relay Timing Patterns*
- *Tone Generation Frequencies & Durations*

Up to six (6) control timing sequences may be programmed into the controller. Standard siren control timings can be chosen or custom relay output timings can be designed. The control functions can be activated from any combination of six (6) Single Tone, Two Tone Sequential and/or DTMF tones. Timing sequences can also be initiated using the local push buttons and contact closure inputs.

Configuration programs are stored in nonvolatile E² memory to ensure retention even during a complete power failure.

1-6. SIGNAL DESCRIPTION

All of the vertical sirens are capable of providing a sustained steady signal, and a wailing signal. The steady signal is frequently used as a Civil Defense "Alert" signal. The wailing signal is often used as a Civil Defense "Attack". However, the signal can be used for any desired indication. These signals are shown graphically in Figure 1-2 for both single tone and dual tone vertical siren models.

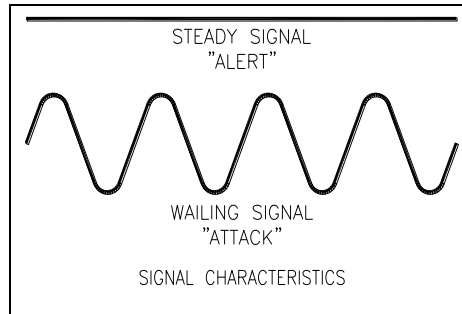

Figure 1-2. Signal Characteristics

SECTION II SPECIFICATIONS

2-1. MODEL 2.

Power Requirements.....	120Vac/dc, single-phase 24A. or 240Vac/dc, single-phase 12A.
Physical	
Diameter	18" (46 cm)
Height	25.5" (65 cm)
Shipping Weight.....	85 lb. (36 kg.)
Miscellaneous	
Sound Output.....	102dBC at 100 ft. (30.5m - Model 2)
Motor Type.....	Single phase ball bearing, universal series 120Vac/dc, or single phase ball bearing universal series 240V ac /dc
Power	2 HP
Top Frequency	
Single Tone	533Hz (60Hz) or 444Hz (50Hz)
Operating Temperature.....	-30° C to 65° C

SECTION III INSTALLATION

DANGER

Electrocution or severe personal injury can occur when making electrical connections, drilling holes, or lifting equipment. Therefore, installation should be performed by experienced electricians in accordance with national and local electrical codes.

3-1. SIREN LOCATION

The information in this section provides guidelines to aid the user in the selection of an installation site that makes the best possible use of the siren.

WARNING

The output levels of the Model 2 siren are capable of causing permanent hearing damage. To prevent excessive exposure, carefully plan placement of siren and post warnings.

If the siren is being installed as part of a Civil Defense Warning system, always follow Federal Emergency Management Agency (FEMA) recommendations.

Careful consideration of the factors affecting the propagation of sound from the siren and the response of the human ear to the sound will optimize the ability of the siren to effectively warn the community.

The reduction of signal intensity, as the distance from the siren increases and the minimum desired signal level at the fringe of the area to be covered are important considerations when choosing a siren installation site. As the distance from the siren increases, sound level losses accumulate. These losses are a result of weather conditions, the terrain, and obstructions in the sound path, the pitch of the sound and the height of the siren. Optimum sound propagation conditions exist when there are no obstructions in the sound path, the terrain is flat, and the air is calm. Under these conditions, each time the distance from the siren is doubled, the sound level decreases by approximately 8dB. For example, the sound level 100 feet (30.5m) from a Model 2 is 102dB, at 200 feet (61m), the sound level drops to 94dB; at 400 feet (122m) the sound level drops to 86dB; etc. This is referred to as the “loss per distance doubled”.

A loss per distance doubled of 8dB is seldom experienced. This is because buildings and other obstructions are frequently present in the sound path. In addition, the atmosphere is rarely calm, and the terrain may not be flat. As a result, a typical loss per distance doubled in residential areas may be 10dB, and as high as 12dB in areas having tall buildings.

Experience indicates that an individual with normal hearing will probably hear a warning signal whose intensity is at least as high as the ambient noise level.

Experience has also shown that the ambient noise level in industrial districts is typically 90dB. Therefore, for a person to hear a warning signal in an industrial area, the sound level intensity of that signal must also be approximately 90dB. In this situation, any point receiving a signal having less than 90dB intensity is considered to be outside the effective range of the siren.

In business districts an ambient noise level of 80dB is common and in residential areas, 70dB of ambient noise is typical. Assuming a 10dB loss per distance doubled and a 70dB minimum sound level, the effective range of a

Model 2 is approximately 910 feet (278m).

Wind speed and direction often affect the propagation of sound from the siren. Consequently, the direction of the prevailing wind may also be a factor to consider when selecting the installation site(s) of a small, one or two-siren system. For example, if the prevailing wind is from the west, it may be desirable to install the siren toward the western edge of the area to be covered.

Other factors to consider before selecting the installation site include the availability of electrical power, the ease of installation and maintenance, and the height of surrounding obstructions.

3-2. PHYSICAL INSTALLATION

WARNING

Moving parts could cause severe cuts or amputation. DO NOT reach into the siren openings.

A. GENERAL

Most siren installations are one of two types; Pole Mount or Flat Surface Mount. These two configurations make it possible to install a siren in almost any situation. If neither of the installations in this paragraph is suitable, modification of one of the configurations described may be necessary. Contact the factory for further assistance.

A siren is typically installed 35 to 40 feet above the ground. If the installation is less than 35 feet above the ground, the sound intensity at close range may increase, but the effective range of the siren may be reduced. Conversely, if the siren is located more than 40 feet above the ground, the effective range of the siren may increase, but the sound may skip over areas closer to the siren. These variables may make it desirable to test the sound coverage of the siren at various heights and locations whenever possible. ALWAYS insure that the air intakes are clear when the siren is being tested and when it is installed at its final location.

1. Model 2 (Pole Mounting)

A Model PMS Pole Mounting Stand is required when mounting the Model 2 on a utility pole. The PMS consists of a mounting plate, three angle iron legs, six 1/2"-13 x 2" hex head cap screws, six 1/2"-13 nuts, and six 1/2" lock washers.

- (a) Uncrate the siren and remove the siren from the shipping base.
- (b) Attach the cast iron legs of the siren mechanism to the mounting plate using 3/8" lock-washers, nuts, and bolts through the 3 slots in the mounting plate (see figure 3-1).
- (c) Set the siren housing over the siren mechanism on the mounting plate. Center the housing over the mechanism. Attach the housing to the plate using aluminum clips, 1/4" lock-washers, nuts, and bolts through the three 3/8" diameter holes (see figure 3-1 and figure 5-8).

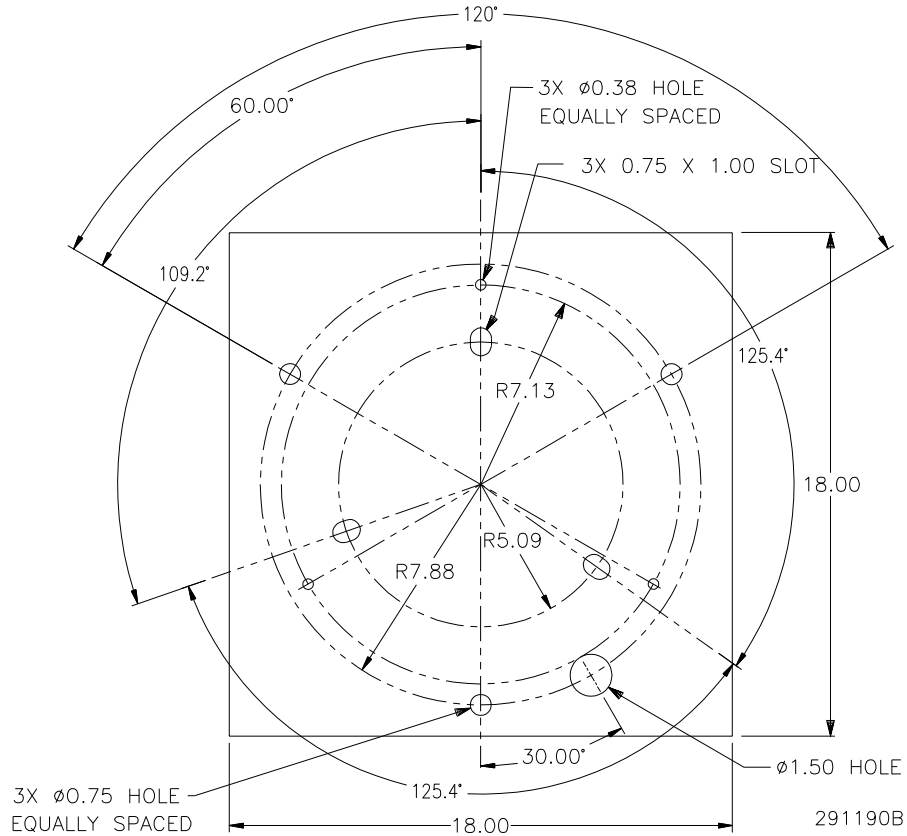

Figure 3-1. Mounting Plate Drilling Detail

(d) Lay the siren mechanism on its side and attach the three legs to the mounting plate using three angle iron clips and six 1/2"-13 nuts and bolts. Attach the legs through three .75" X 1" slotted holes indicated in figure 3-1.

(e) Dig the hole for the Class 2 utility pole and lay the pole on the ground as close as practical to the installation site.

(f) With the siren laying on its side, and the pole laying on the work surface attach the siren to the utility pole using at least two 5/8" lag bolts at least four inches long (not supplied) for each leg. If necessary, install shims between the siren legs and the pole.

(g) Wrap a cable or chain capable of bearing at least one ton around the pole-siren combination at least three times. Wrap the chain or cable around the legs of the siren. Use the chain or cable in conjunction with a crane or hoist capable of lifting at least one ton to erect the pole in accordance with accepted practice.

(h) Install the Model RC2W Motor Starter and a fused disconnect switch in a location on the pole that is readily accessible to service personnel, but discourages vandalism. The RC2W must be installed in a vertical position for proper operation. Install the electrical devices following NEC recommendations and local electrical codes. A suggested installation configuration is shown in figure 3-2.

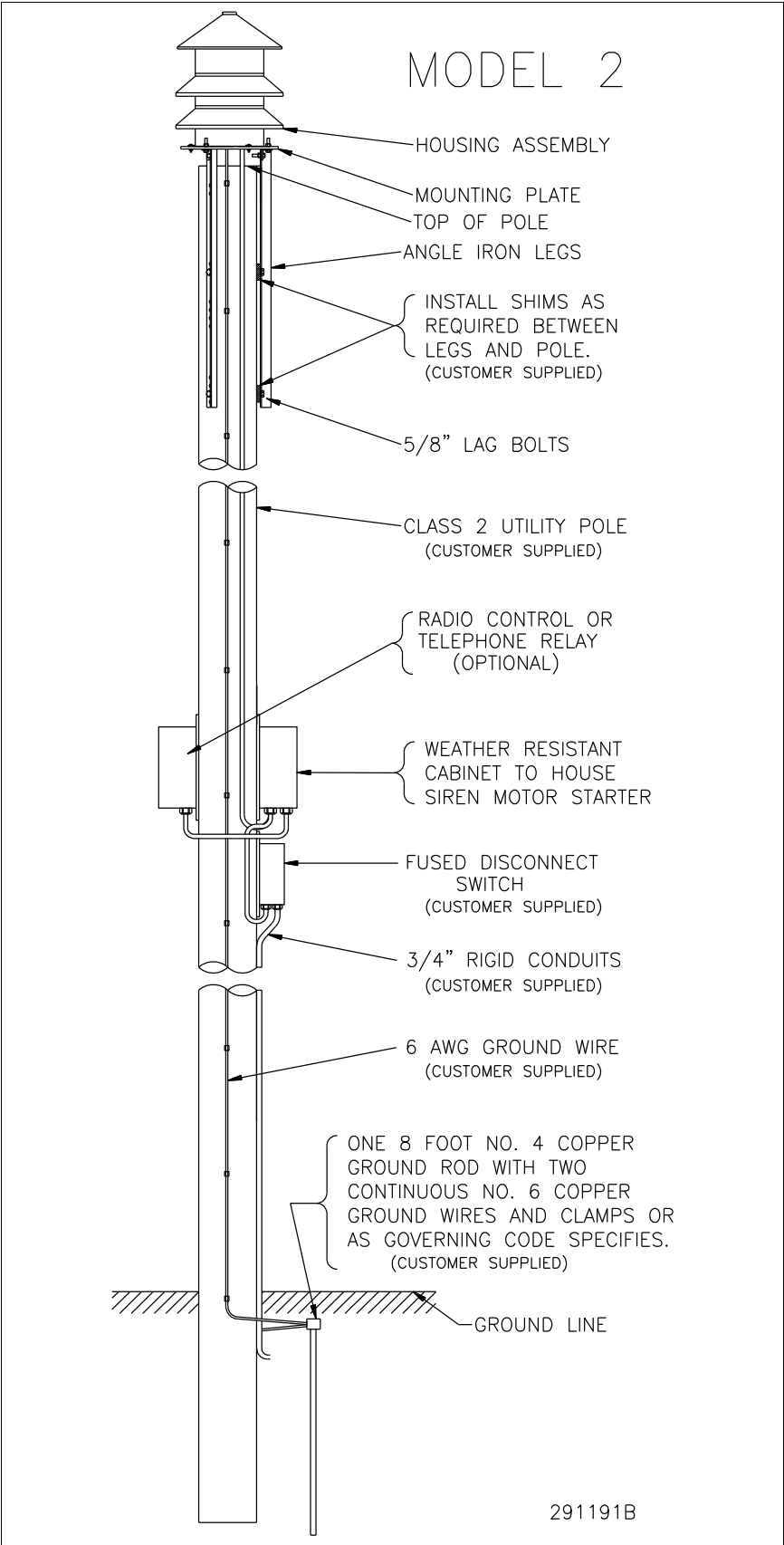

Figure 3-2. Typical Model 2 Pole-Mounted Installation

2. Model 2 (Flat Surface Mounting)

WARNING

Moving parts could cause severe cuts or amputation. DO NOT reach into the siren openings.

(a) Center the siren mechanism on the mounting surface, and using the mounting holes in the legs of the mechanism as a template, drill three 7/16" holes in the mounting surface (see figure 3-3).

(b) Temporarily set the siren housing over the siren mechanism on the mounting plate. Center the housing over the mechanism.

(c) Using the housing and the aluminum clips as a template, drill three 1/4" holes approximately equidistant around the circumference of the housing. Lift the housing off of the siren. It will be reinstalled later.

(d) Mount the siren-base plate assembly on the mounting surface using lag bolts or nuts and bolts, as appropriate. Do NOT replace the housing on the siren. It will be replaced later. If the siren is mounted directly on a roof (without a platform or weight distribution mat) be sure to install waterproof joints where the mounting bolts pass through the roof so that water does not enter the building.

(e) Install the RC2W Motor Starter, fused disconnect switch, and other control devices as close as practical to the siren following local electrical codes and NEC recommendations. If the siren is installed on the roof of a building, it may be desirable to install the RC2W and other control devices inside of the building. The unit must be installed vertically to operate correctly (see figure 3-3).

MODEL 2

CUSTOMER SUPPLIED *

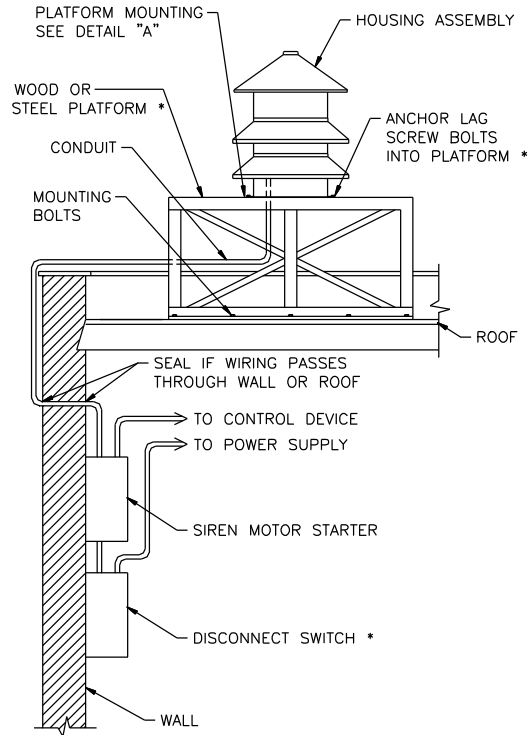

DETAIL "A"

PLAN VIEW

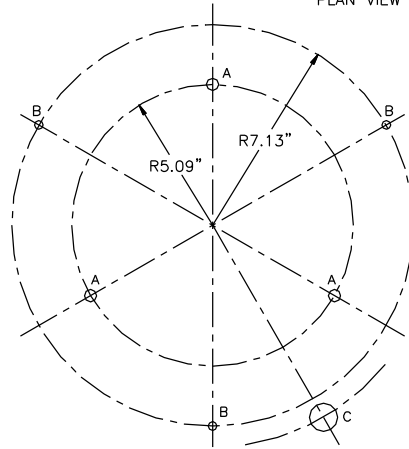

- ⊕^A DRILL 3 HOLES 7/16 DIA. FOR MODEL 2 LEGS
- ⊕^B DRILL 3 HOLES 5/16 DIA. FOR MOUNTING CLIPS
- ⊕^C DRILL 1 HOLE FOR CONDUIT

291194A

Figure 3-3. Typical Model 2 Platform Mount

3-3. ELECTRICAL CONNECTIONS.

Note: For FC, FCTB controller connections refer to their installation manuals 255294, 255326.

DANGER

Electrocution or severe personal injury can occur when making electrical connections, drilling holes, or lifting equipment. Therefore, installation should be performed by experienced electricians in accordance with national and local electrical codes.

The power and control circuitry of a typical Model 2 installation is shown in figure 3-4. The schematic diagram of the Model RC2W Motor Starter is also shown in the figure.

The RC2W Motor Starter is provided with various size knockout holes. Some of the knockouts can accommodate 1/2" conduit fittings, others can accept 3/ 4" conduit fittings, and still others can accommodate 1" conduit fittings. These various sized knockout holes are provided because electrical wiring requirements are frequently unpredictable. The diameter of the conduit required for the installation depends on the AWG size of the wiring used, the type of insulation on the wiring, and local electrical codes. Therefore, be sure that the size of the conduit selected meets the requirements of the installation.

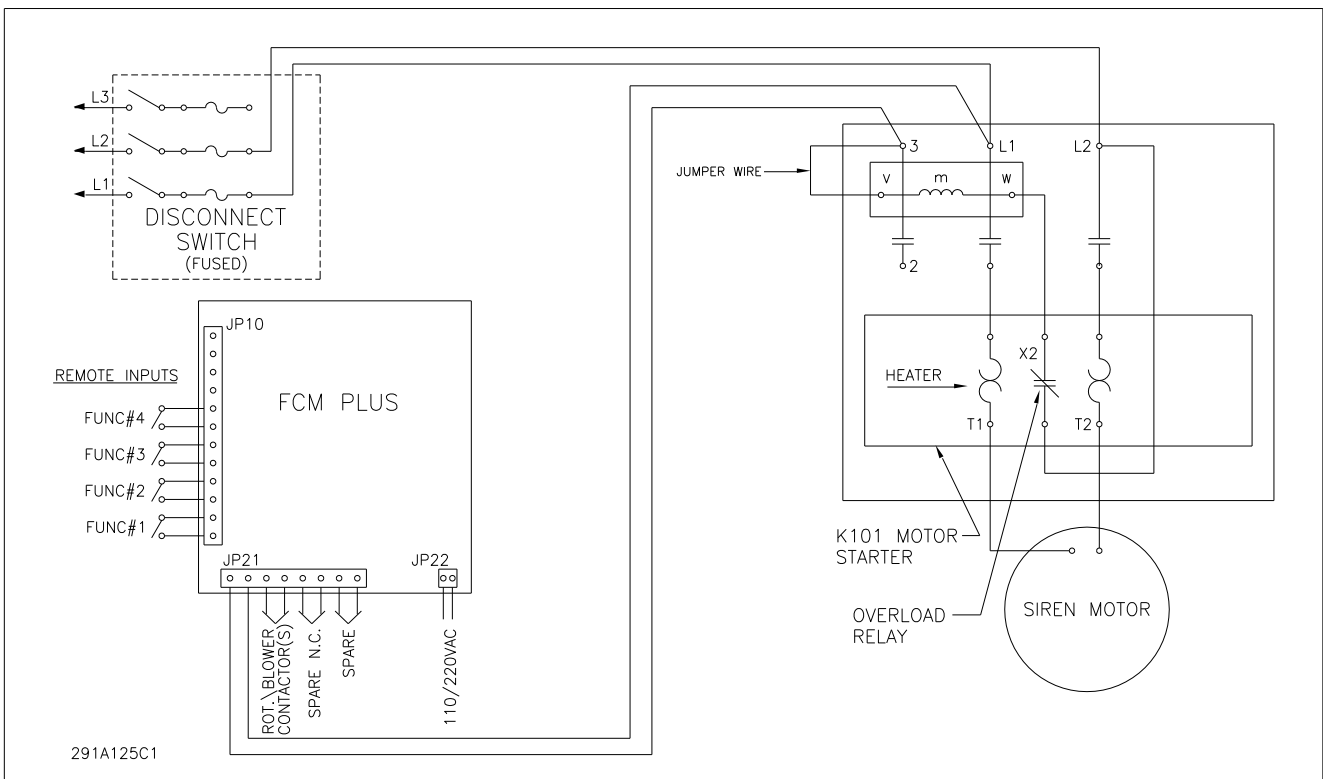

Figure 3-4. RC2W Electrical Connection

To connect the motor starter and siren to the power source and control circuitry, proceed as follows (see figure 3-4):

1. Install conduit between the RC2W and the electrical leads on the side of the siren motor.
2. Install conduit between the RC2W and the disconnect switch.

3. Install conduit between the disconnect switch and the electrical power source. If the siren is installed on a utility pole, add an entrance cap to the end of the conduit, as shown in figure 3-2.
4. Route two wires of the proper size from T1 and T2 in the RC2W, through the conduit to the siren motor leads.
5. Route two wires of the proper size from L1 and L2 through the conduit to the power disconnect switch.
6. Route two wires, of the proper size, from the disconnect switch to the power source.
7. Connect the FC to terminals L1 and 3 in the motor starter. See figure 3-4.
8. Replace the housing on the siren.
9. As a safety precaution to protect both personnel and equipment, it is highly recommended that the siren and all control devices be solidly connected to an earth ground. If the siren is installed on a building, ground the system to a metallic object known to be grounded. For pole mounted installations, drive a metal rod or bar at least two feet (61 cm) into the ground, or as close as practical to the base of the pole. For maximum protection, use a separate, continuous 10AWG or larger, wire from the siren frame to ground and the cabinet of each control device to ground.

3-4. PREOPERATION CHECKS

After the siren has been completely installed, perform the following checks before putting the siren into service.

WARNING

The output level of a siren is capable of causing severe hearing discomfort or permanent hearing damage. Therefore, ALWAYS wear hearing protection when performing tests or maintenance on the siren.

- A. Make sure that all air intakes and sound outlets are not obstructed.
- B. For local test activation refer to the FC control installation manual no. 255294.
- C. Check the operation of the control circuitry by initiating one or more signals from the FC control.

After the installation is complete and it has been established that the siren is operating properly, Federal recommends that all control devices be padlocked to discourage tampering and vandalism.

SECTION IV CIRCUIT DESCRIPTION

4-1. SIREN CONTROL DESCRIPTION

The Model RC2W is used to operate a Model 2 Siren.

The RC2W is a motor starter that switches the power to the Model 2 siren. The RC2W requires a siren controller to provide Steady and Wail type siren signals typically used for warning applications. The siren controller will hold a contact closed to activate the RC2W for a Steady signal and will cycle the contact open and closed to create a Wail signal. The RC2W also provides overload protection for the siren motor.

As shown in figure 3-4, the motor starter includes an overload relay. The relay protects the motor starter and the motor in the event that excess current is drawn. The overload relay is activated when there is sufficient current through one or more of its heaters to cause the heater(s) to expand enough to open the relay contacts. The opening of the relay contacts opens the motor starter control circuit. As a result the motor starter de-energizes, protecting the circuit against damage. After the motor starter de-energizes, the relay contacts reset automatically when the heater(s) cools sufficiently. The overload relay can also be reset manually after approximately one minute.

SECTION V

SERVICE AND MAINTENANCE

5-1. GENERAL

WARNING

Service or maintenance should be performed by qualified personnel familiar with the siren, associated controls, and power sources being used. The siren has moving parts and high operating currents that could cause severe personal injury, electrocution, or death. Before servicing or maintaining, ensure that remote activation cannot occur and disconnect power to the siren and its controls.

The Model 2 Siren is designed to require a minimum of maintenance. In addition, experience has shown that all Federal Signal sirens are highly reliable devices. However, if a siren failure does occur, Federal Signal will provide technical assistance with problems that cannot be handled locally. If assistance is desired, contact:

ANS Customer Care Center
Signal Division
Federal Signal Corporation
2645 Federal Signal Drive
University Park, Illinois 60484
800-524-3021

5-1.A MINIMUM RECOMMENDED INSPECTION

Test the siren for proper operation at least once a month. A daily test at noon, curfew, or other selected time is preferred. This not only enhances the usefulness of the siren, but also instills public confidence in the reliability of the warning system.

5-1.B ANNUAL INSPECTION

In order to minimize the possibility of siren failure, inspection and maintenance at regular intervals is desirable. Therefore, it is recommended that the procedure in this paragraph be performed at least once a year. However, it may be necessary to increase the frequency of this procedure if the siren is used frequently or if it is used in an extreme climate.

1. Remove the housing and inspect the motor brushes. Replace the brushes if necessary.
2. Inspect all electrical and mechanical connections. Make sure that all fasteners are properly tightened.
3. Inspect the siren installation to be sure that it is vertically oriented. Take corrective action if a pole mounted installation is more than 5° from vertical or a roof or flat surface mount is more than 10° from vertical to prevent lubrication losses and excessive motor bearing wear.
4. Examine all painted surfaces. Repaint as necessary.

5-2. CORRECTIVE MAINTENANCE

A. Troubleshooting

The Troubleshooting Chart (Chart 5-1) is provided to assist repair personnel when troubleshooting a siren malfunction. This section also includes diagrams that may be helpful if the siren or control devices need repair.

WARNING

Moving parts could cause severe cuts or amputation. DO NOT rotate the commutator by sticking your fingers in the stator ports and pushing on any part of the rotor.

B. Model 2 Motor Brush Replacement

1. Loosen the clips that hold the siren housing to the mounting surface. Lift off the housing.
2. Remove the insulated cap from the Armature Brush Holder and slide out the worn armature brush. Do not loosen or remove the brush holder.
3. Install the replacement brush and replace the cap. Ensure that the brush is properly seated as indicated in figure 5-1, before tightening the cap. Make sure that the cap seats properly. However, do not tighten the cap excessively, or it may break.

C. Model 2 Armature and Field Replacement

1. Armature

- (a) Turn off the power to the siren at the disconnect switch.
- (b) Remove the siren housing from the mechanism.
- (c) Disconnect the electrical power wiring from the siren motor.
- (d) Remove the mechanism from the mounting surface. If desired, the legs can also be removed from the mechanism.
- (e) Remove the four bolts holding the chopper rotor and armature to the stator. Lift out the rotor and armature.
- (f) Remove the lock nut and lock washer from the armature.
- (g) Use a bearing puller to pull both roller bearings from the armature shaft.
- (h) Use a hydraulic press to separate the armature from the chopper rotor.
- (i) When installing a new armature it may be necessary to change the electrical connections of the field. Therefore, refer to the instructions included with the replacement armature for the correct field connections.
- (j) Install the replacement armature and reinstall the siren following steps (a) through (h) in reverse.

2. Field

- (a) Turn off the power to the siren at the disconnect switch.
- (b) Remove the siren housing from the mechanism.
- (c) Disconnect the electrical power wiring from the siren motor.
- (d) Remove the siren mechanism from the mounting surface. If desired, the legs can also be removed from the mechanism.
- (e) Remove the field-retaining ring from the motor housing.
- (f) Arrange two spacers consisting of 4" x 4" (102mm x 102mm) lumber or similar material, approximately 5" (127mm) apart on a solid work surface as shown in figure 5-2.
- (g) Sharply rap the motor housing against the spacers several times until the field drops out of the motor housing. The motor housing is aluminum die-casting. As a result, it can be broken or damaged. Therefore, use caution to ensure that the motor housing strikes the spacers squarely as indicated in figure 5-2.

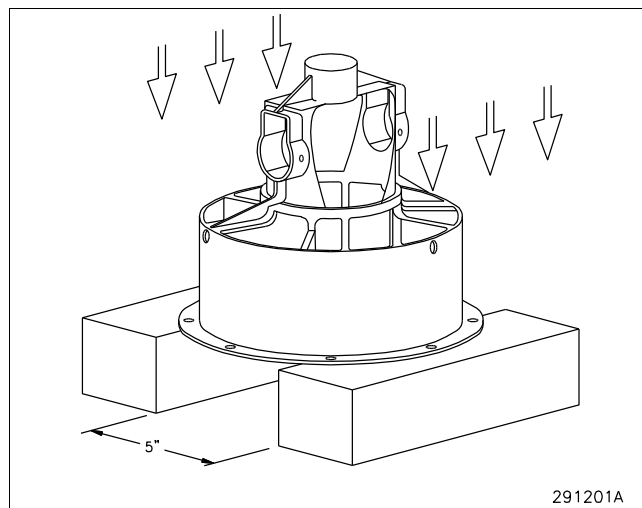

Figure 5-2. Model 2 Field Removal

NOTE:

It is not necessary to follow the procedure described in steps (h) through (k) if a hydraulic press is available to press the replacement field into the motor housing.

(h) Fabricate two 8" (203mm) guide pins from 3/16" (5mm) metal rod. Taper these pins as indicated in figure 5-3.

(i) Insert the tapered end of the pins into the threaded holes in the field holder ring as indicated in figure 5-3.

(j) Set the new field on the motor housing with the guide pins passing through the two mounting holes in the body of the field as shown in figure 5-3. Be sure that the four wires are in the position shown in figure 5-3.

(k) Set a length of 3/8" (9.5mm) steel bar stock approximately 5" (127mm) long, or similar object, on the field as illustrated in figure 5-3. Drive the field into the motor housing by firmly and squarely tapping the bar with a hammer. See figure 5-3. Use caution to avoid cutting or otherwise damaging the wires that are connected to the field.

(l) Connect the two wires having rings to the motor brush holders, one wire to each brush holder.

(m) Reinstall the field-retaining ring.

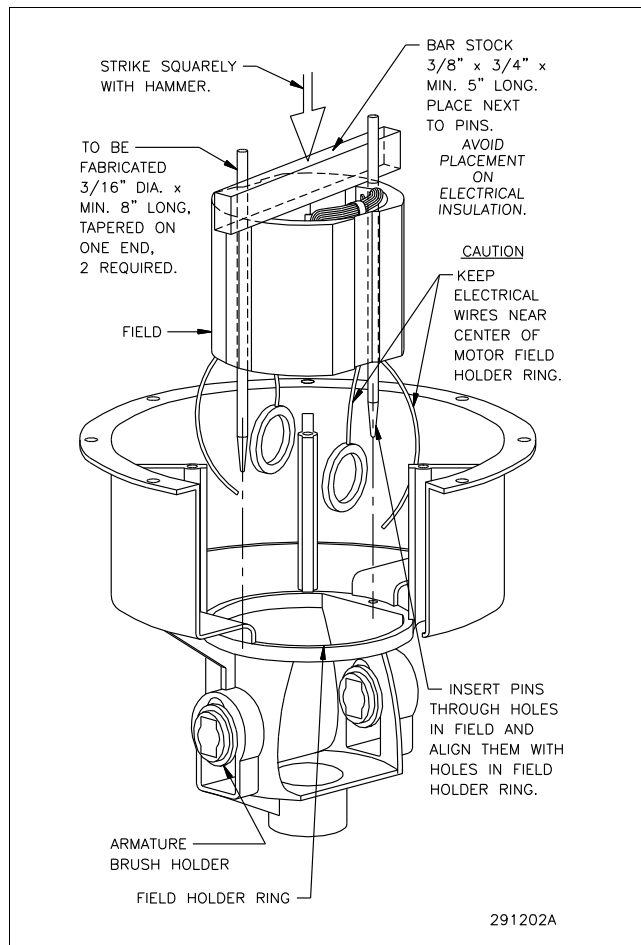

Figure 5-3. Model 2 Field Replacement
POSSIBLE CAUSE

TROUBLE

REMEDY

Siren motor inoperative.	Motor starter overload relay tripped.	Reset relay
	Open circuit between motor starter and Motor.	Check wiring for continuity.
	Rotor jammed	Check rotor for free rotation. Remove material causing jamming.
	Siren motor defective.	Check motor, and repair or replace, if necessary.
	Faulty Overload Heater(s)	Replace
Motor starter inoperative.	Faulty motor starter control winding	Replace coil
	Motor starter overload relay tripped	Reset relay
	Faulty overload heater(s)	Replace heater(s)
	Open circuit between disconnect switch and motor	Check wiring for continuity. Repair or replace wiring as necessary.
	Open circuit between control equipment and motor	Check wiring for continuity. Repair or replace wiring, as necessary.
	Faulty control device(s)	Repair or replace, as necessary.
	<i>Chart 5-1. Troubleshooting Chart</i>	

**PPL 0053
PARTS LIST**

MODEL 2 SIREN

MAY 1989

Index No.	Description	Part No.	Qty.
1	Housing Assembly, Galv. Steel	8155B086	1 AR
2	Projector	8247C006	1
3	Plug	8283A120	1
4	Plate, Baffle	8247C007	1
5	Taper Pin, # 5 x 1	8400A229	2
6	End Bell, Stator	L01-02	1
7	Locknut	L01-15	1
8	Lockwasher	L01-16	1
9	Bearing	8239A045	2
10	Mounting Clip	8155109A	3
11	Rotor Spacer and Bearing Stop	L01-08	1
12	Rotor	L01-21	1
13	Key	8247A057	1
14	Armature, (120V)	8247B041G	1 AR
	Armature, (240V)	8247B039G	
15	Locking Ring, Field	L01-20	1
16	Field, (120V)	8247B042G	1 AR
	Field, (240V)	8247B040G	
17	Spring Lockwasher, Lower Bearing	L01-11	1
18	Holder, Brush	8247A021	2
19	Brush and Spring	8247A020	2
20	Cap, Brush Holder	8247A022	2
21	Housing, Motor	L01-03	1
22	Legs	L01-4A	3
23	Hanger, Cable	8400A211	1

DO NOT ORDER PARTS BY INDEX NUMBER.

Give model, voltage, description, and part number.

Federal Signal Corporation
Signal Division
2645 Federal Signal Drive
University Park, Illinois 60466

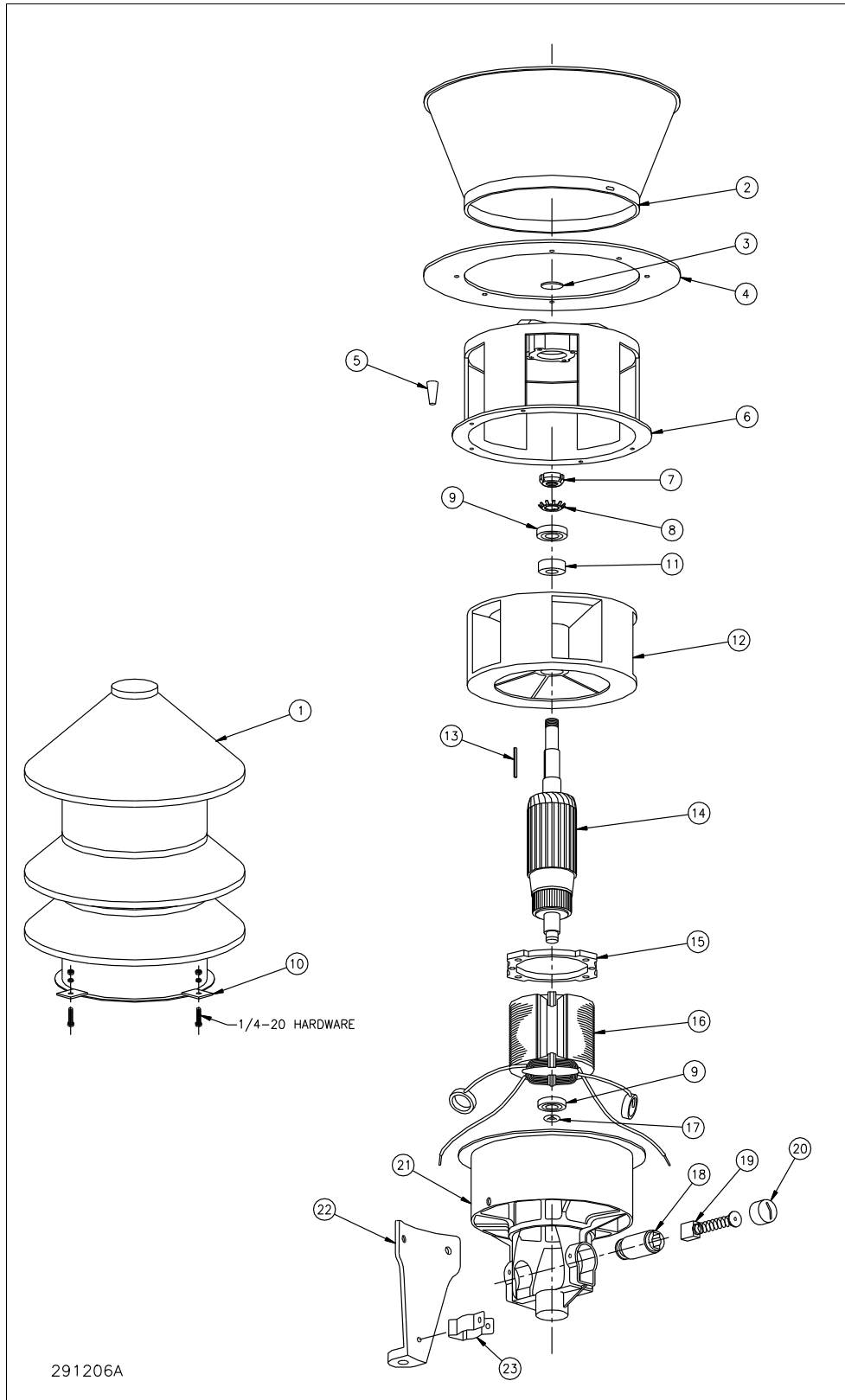
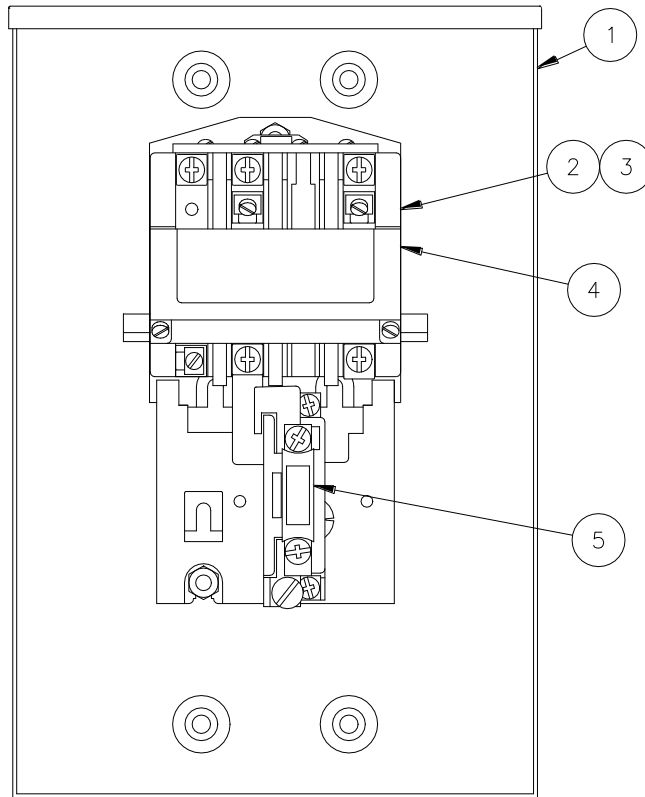

Figure 5-6. Model 2 Parts Index



291208A

Figure 5-8. Model RC2W Parts Index

**SIREN REMOTE CONTROL
MODELS: RC2W-120 and RC2W-240**

PPL 0062 PARTS LIST

JANUARY 1986

Item No.	Description	Part No.	Qty.
1	Cabinet, NEMA Type R3	170272B	1
2	Contacts and Springs (Power Pole)	8217C182-11	2 sets
3	Contacts and Springs (Interlock)	8217C180-12	1 set
4	Coil, 60 Hz, 120/240V	8217C180-16	1
5	Overload Heaters (K-58) 120V	8217C182-20	1
	Overload Heaters (K-42) 240V	8217C183-20	1

DO NOT ORDER PARTS BY ITEM NUMBER. Give model, voltage, description, and part number.
Federal Signal Corporation Signal Division, 2645 Federal Signal Drive, University Park, Illinois 60466



MICROWATT

Making Safety Work

Tollfree in Western Canada: 1-888-388-1592
microwatt.com • mwsales@microwatt.com